

# ARITERM



## INSTALLATION AND OPERATING INSTRUCTIONS

- ✦ Ariterm Biomatic+ 20 Light
- ✦ Ariterm Biomatic+ 20 Ultra Light



## ■ TABLE OF CONTENTS

General information .....	2
Transport, storage and package opening.....	2
Technical data.....	3
Functional description.....	4
Safety and alarms .....	4
Control panel.....	5
Burner operating principle .....	5
Boiler installations .....	6
Pipe installations.....	7
Wiring diagram, Light.....	8
Wiring diagram, Ultra Light .....	9
Start-up and stop.....	10
Burner settings .....	11
Burner parts.....	11
Menu structure.....	12-15
Heating circuit settings .....	16
Heat regulation examples.....	17
Heat Regulation menu structure .....	17
Alarms and troubleshooting.....	18-19
Decommissioning .....	20
Most common spare parts.....	20
Service and maintenance.....	21-22
Wood pellets as fuel.....	23
Feeding system .....	24
Declaration of conformity.....	25
Installation record.....	26
Notes .....	26-31

## ■ GENERAL INFORMATION

Ariterm Biomatic+ is a cost-effective, resistant and environmentally friendly combination of a central heating boiler and a pellet burner intended for use for the heating of single-family detached houses and the production of hot domestic water using pellets. Additional/backup heat is produced by an incorporated electrical resistance (6 or 9 kW). Standard equipment includes an automatic convection cleaning system and an automatic heating circuit regulation system. Detailed technical data can be found on page 3. To make use of all features of the boiler and burner, it is important to observe these instructions.

Keep this manual in a safe place for future reference. Read this manual carefully before starting to use your Ariterm Biomatic+ pellet heating centre. The power of the pellet burner depends on how many pellets can be fed into and burned in the burner head during one hour. (This means burning of wood pellets of the usual kind, which approximately comply with the fuel specifications described in this manual.)

Please note! Follow the recommendations contained in this manual when using and servicing the burner and the boiler.

### ■ TRANSPORT, STORAGE AND PACKAGE OPENING

#### Receipt and acceptance

The boiler is delivered in a wooden frame. The base is a platform from which the boiler can be safely lifted. The package should be unwrapped as close to the installation site as possible. The factory has insured the boiler against damage during transport from the factory to the first intermediate storage site. It is important for the person who receives the boiler to verify the state of the boiler before its acceptance. In case of damage, the dealer must be contacted without delay.

#### Storage

The boiler can be stored outside under a rain cover for a short period of time. However, the preferred option is to store it inside.

#### Package opening

After opening the package, open the hatch and check the accessory list to make sure that all loose accessories are contained in the package (cleaning brush handles are attached to the package).

#### Disposing of the package

The plastic cover is landfill waste and the boards can be burned.

## TECHNICAL DATA ARITERM BIOMATIC+ 20 LIGHT / ULTRA LIGHT

### Standard delivery

- Four-way mixing valve ESBE TM 20
- Sweeping gear
- Dirt trap
- Brick support
- Flue duct joint
- Shunt motor ESBE ARA661 3-point SPDT 230Vac 6Nm 120s
- Outdoor temperature sensor
- Indoor temperature sensor
- Supply water temperature sensor
- Automatic convection cleaning system
- Flow switch (not Ultra Light)
- Flue gas fan

### Accessory

- Combined flue duct
- Oxygen measurement (blower power adjustment)
- Shunt motor 2 ARA661 3-point SPDT 230Vac 6Nm 120s
- Supply water temperature sensor 2

### TECHNICAL DATA

<b>Performance</b>	Power with pellets Power with oil (different burner) Combustion efficiency	8-20 kW 20 kW 91%
<b>Dimensions</b>	Dimensions (width x depth x height) Empty weight Water volume	601 x 944 x 1,509 mm 245 kg 140 l
<b>Design and adjustment values</b>	Working pressure: boiler Working pressure: heat exchanger Working temperature Recommended vacuum in the flue pipe	0.5-1.5 bar max 10 bar max 120 °C min 18 Pa, max 25 Pa
<b>Connections</b>	Additional heating circuit unit Domestic water Expansion Discharge Flue pipe connection Recommended flue pipe diameter and length	DN 25 male Cu Ø 22 mm DN 25 male DN 15 female Ø 102 mm Ø 100 mm steel pipe or equivalent, length min 6 m
<b>Electrical values   burner side</b>	Power supply Supply cable Fuse size Power in operation  Power in connection	230 V, 1-phase, 50 Hz MMJ 5x1.5s 10 A Burner, ignition 500 W Burner, normal 40 W 1000 W (depending on equipment)

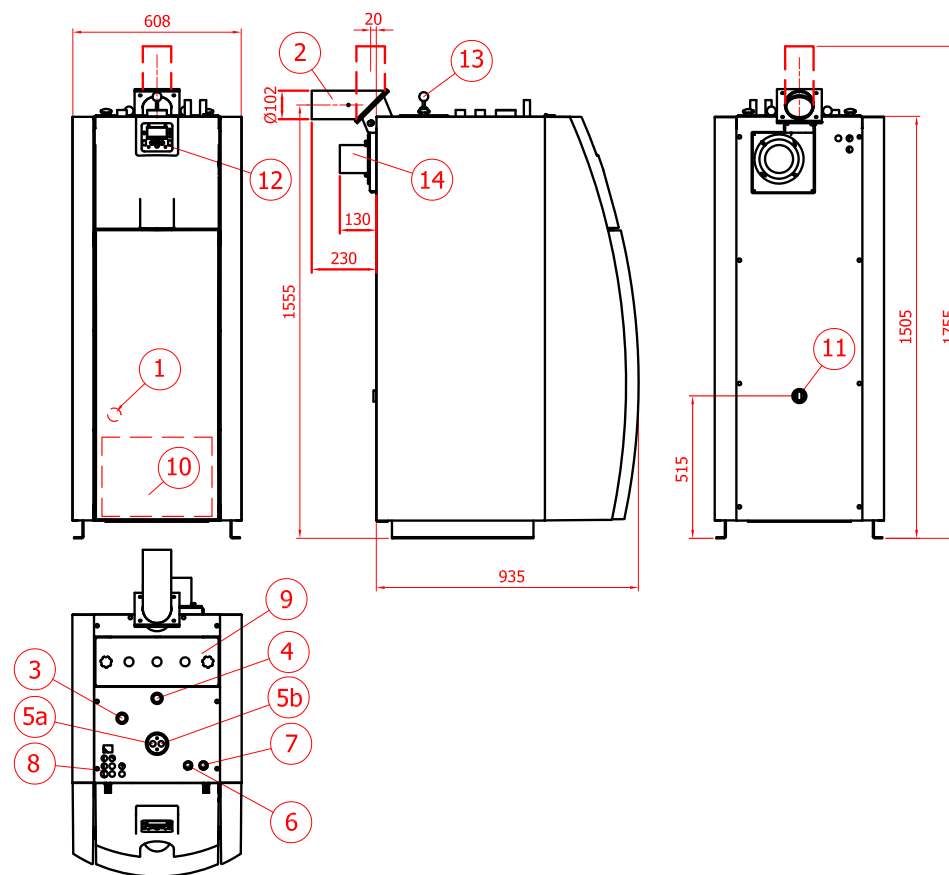

1. Discharge valve DN 15, female
2. Flue duct Ø 102 mm
3. Additional heating circuit unit DN 25, male
4. Expansion unit DN 25, male
- 5a. Heating circuit four-way mixing valve supply
- 5b. Heating circuit four-way mixing valve return
6. Cold domestic water 22 mm Cu (not Ultra Light)
7. Hot domestic water 22 mm Cu (not Ultra Light)
8. Electrical connections
9. Cleanout hatch
10. Ash box
11. Return DN 25, female
12. Display / keyboard
13. Convection sweeper
14. Flue gas blower

## FUNCTIONAL DESCRIPTION

Heating with the Ariterm Biomatic+ pellet heating centre is similar to oil heating in many ways. The main difference is that heating with solid fuel produces a certain amount of ash, which must be removed at certain intervals. If the ash is not removed, combustion efficiency will decrease and the burner may malfunction.

The BeQuem pellet burner is equipped with automatic ignition. However, it can also be ignited manually when necessary. The electric ignition system of the burner will only be activated during cold starts, i.e., when the system has been inactive for a long period and the boiler temperature has dropped to at least 8°C below the target temperature. During the heating process, the necessary ignition cycles take place by means of the embers in the burner head. This saves electric energy.

The burner and the incorporated feeding system operate automatically. The operation of the burner is controlled by the temperature sensor installed in the boiler. The burner head contains an accurately defined mixture of fuel and air, which ensures perfect combustion which is both cost-effective and environmentally friendly.

The auger burner is over-pressurised during operation. The purpose of this is to reduce the risk of damage to the burner if the draught is weak.

Wood pellets with a diameter of 8 millimetres are the recommended fuel for the burner.

Ash is removed from the ash box located in the lower part of the boiler. Ash can also be removed into a special ash pan by means of an ash trap or a common vacuum cleaner. However, the ash may still be hot. Therefore, the ash trap must be heat-resistant.

Standard equipment includes an automatic heat regulation system that adjusts the supply water temperature according to the temperature outside.

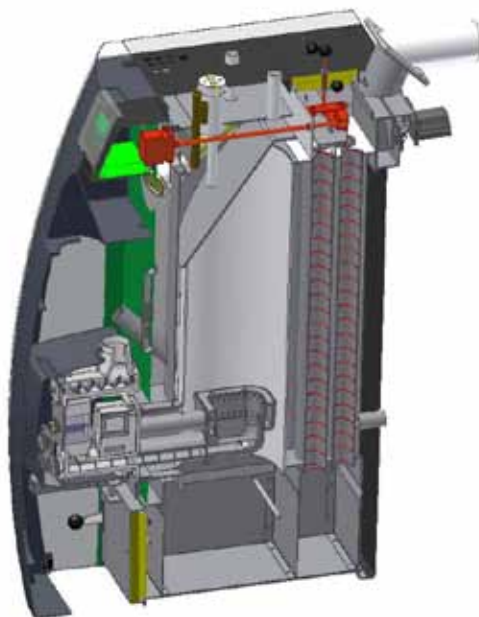

## SAFETY AND ALARMS

For safety reasons, the pellet heating centre and fuel store must be placed apart from each other to prevent possible damage. Any malfunctions or damages caused by incorrect handling will then be limited to the burner. The fuel store must be built as a separate, fire-classified, confined space.

Faults that cause the system to stop are indicated by a red indicator light. In addition to this, a text message appears on the display indicating the cause of the fault.

During every operating cycle, a small amount of pellets (150 g) is fed from the pellet store via the external feeding system to the upper connection of the burner. To make it possible to dispense an accurate and equal amount of pellets during every cycle, the dispensing is carried out by means of a separate feeding auger via the blocking feeder and auger burner to the burner head.

As the auger burner feeds pellets forward three times faster than they arrive at the auger, a safety zone, containing only single pellets, is created between the burner head and the upper connection. This safety zone always remains intact even in the event of power failure, insufficient maintenance or equipment breakage.

*Alarms are described in "Troubleshooting".*





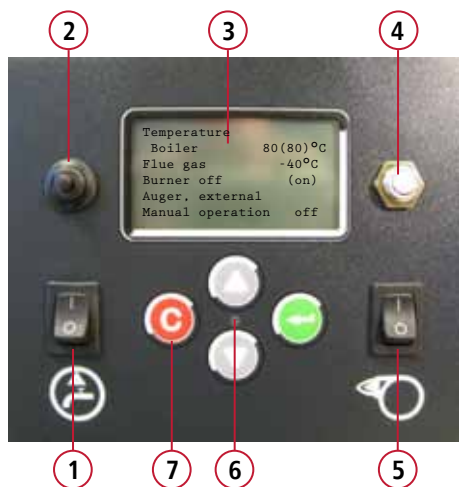

The feeding auger must be installed in such a way that its position with respect to the drop funnel enables the drop pipe to hang free outside the burner should a fire occur in the back.



## CONTROL PANEL



1. Inner circulation pump switch (not Ultra Light)
2. Inner circulation pump fuse (not Ultra Light)
3. Display
4. Over heating sensor
5. Main switch
6. Operation and alarm indication by means of an indicator light
7. Operation button

-  **Green:** The burner is on
-  **Red:** Alarm (the burner is off)
-  **Blinking light:** Warning light (do not turn the burner off)
-  **Arrow keys:** browsing menus / changing set values.
- 
-  **C button:** exiting menus / acknowledging warnings
-  **Enter button:** selecting settings / accepting set values.

## BURNER OPERATING PRINCIPLE

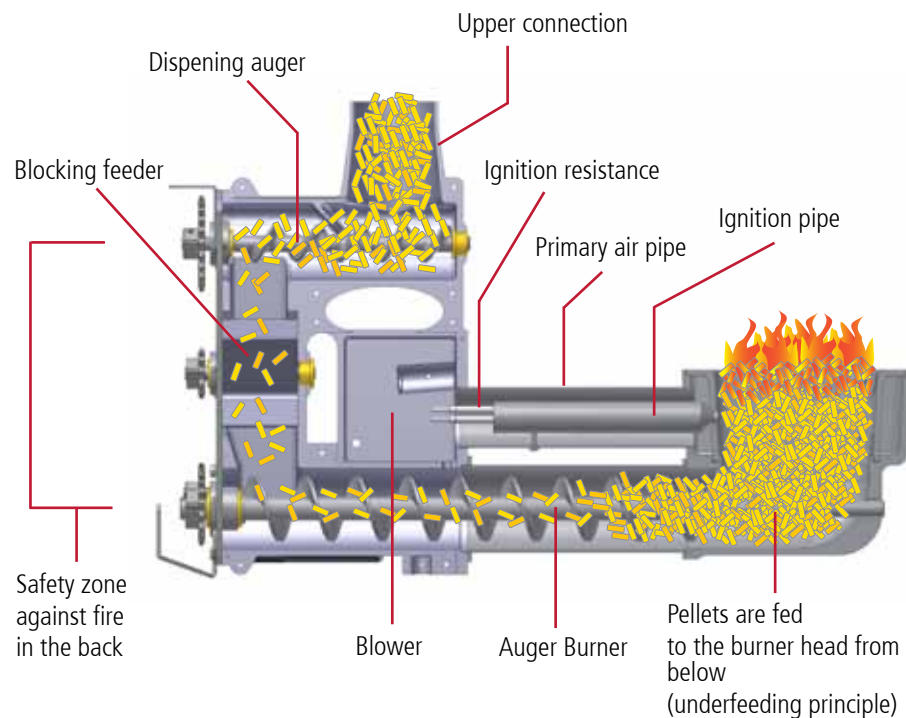

## ■ BOILER INSTALLATIONS

The boiler should be installed by a company with the proper professional qualifications. The installation must always be carried out in accordance with, at the time being, valid local standards and regulations.

### NOTE!

All electrical connections must be carried out by a professionally-qualified electrician.

### ■ Space requirement

The boiler room must always meet, at the time being, valid local standards and regulations. At least one meter of free space is recommended to be left in front of the boiler for cleaning and maintenance operations. It is also recommended to leave about 80 cm of free space on the other side and at least 50 cm above the boiler.

### NOTE!

The boiler must be located at a distance of no less than 180 mm from the back wall. In addition, it must be possible to remove the flue gas blower whenever maintenance requires it.

### ■ Flue pipe connection and combustion air intake

Silicon sealant with a temperature resistance of 350°C can be used as a sealing compound for joints. The flue pipe must be made of steel or equivalent material. The flue pipe length must be dimensioned according to the building requirements. The ventilation air intake must not be covered.

Flue pipe connection and ventilation air intake	
Recommended flue pipe diameter	Ø 100 mm
Flue pipe length	6 m
Recommended vacuum in the chimney	min 18 Pa, max 25 Pa
Ventilation air intake	100 cm <sup>2</sup>

## ■ BOILER INSTALLATIONS

### ■ Pipe installations

Before installing the boiler, the heating network must be flushed and checked by means of a water-pressure test. After installation, make sure that all joints are tight. The factory is not responsible for damages caused by leaking joints.

### ■ Dirt trap and manometer installation

It is recommended that the dirt trap delivered with the boiler be installed in the cold water pipe before the heat exchanger. There is no manometer in the boiler. Therefore, it must be installed in the heating network.

### ■ Safety valve installation

The valve must be CE marked. Its maximum opening pressure must be 1.5 bar and its minimum size DN 15. The safety valve must be chosen according to the highest pressure class of the combination of devices. Devices that can close the connection must not be installed between the valve and the boiler. The blowdown pipe must be dimensioned and installed in such a way that it does not limit the valve blowdown efficiency and does not cause dangerous situations during the operation of the valve.

### ■ Electrical installations

A pellet burner, a 6/9 kW electrical resistance and an internal circulation pump with its switches are installed in the boiler and are ready for use. The boiler contains an overheat protection for the burner and the electrical resistance. The electrical installations related to the boiler must be carried out by an installer with the relevant qualifications. The connection is carried out according to the enclosed connection diagram. A safety/maintenance switch must be installed in the voltage supply system of the boiler.

### ■ Before commissioning

Before starting the boiler, the following should be checked:

- the heating network and the boiler are full of water (pressure at least 0.5 bar).
- air is removed from the internal circulation pump through the venting screw located in the pump head.
- the flue damper (if any) is open.
- the circulation damper located in the convection part of the boiler is in place.
- the circulation pump is running.
- the network valves are open.
- the ventilation air intake is open.
- the safety valve is in working order and there are no obstacles between it and the boiler.

## PIPE INSTALLATIONS

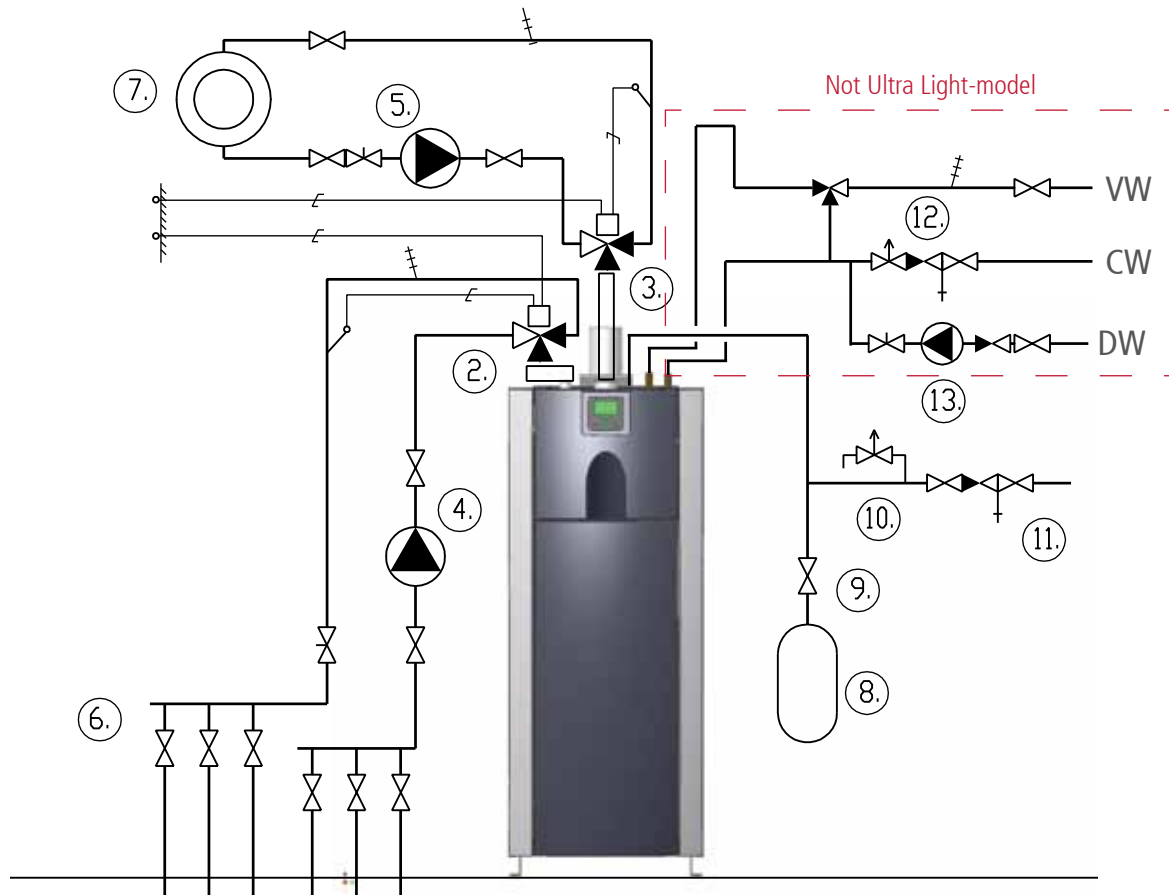

1. ARITERM BIOMATIC+
2. 4-WAY VALVE, FLOOR HEATING (RADIATOR HEATING)
3. CONNECTION SET OF THE ADDITIONAL HEATING CIRCUIT (RADIATOR HEATING)
4. HEAT PIPE PUMP, FLOOR HEATING
5. HEAT PIPE PUMP, RADIATOR HEATING
6. FLOOR HEATING NETWORK MANIFOLDS
7. RADIATOR HEATING NETWORK
8. EXPANSION VESSEL
9. SERVICE SHUT-OFF VALVE
10. SAFETY VALVE
11. FILLING VALVE
12. FEED MIXING VALVE
13. DOMESTIC WATER CIRCULATION PUMP

# WIRING DIAGRAM - LIGHT

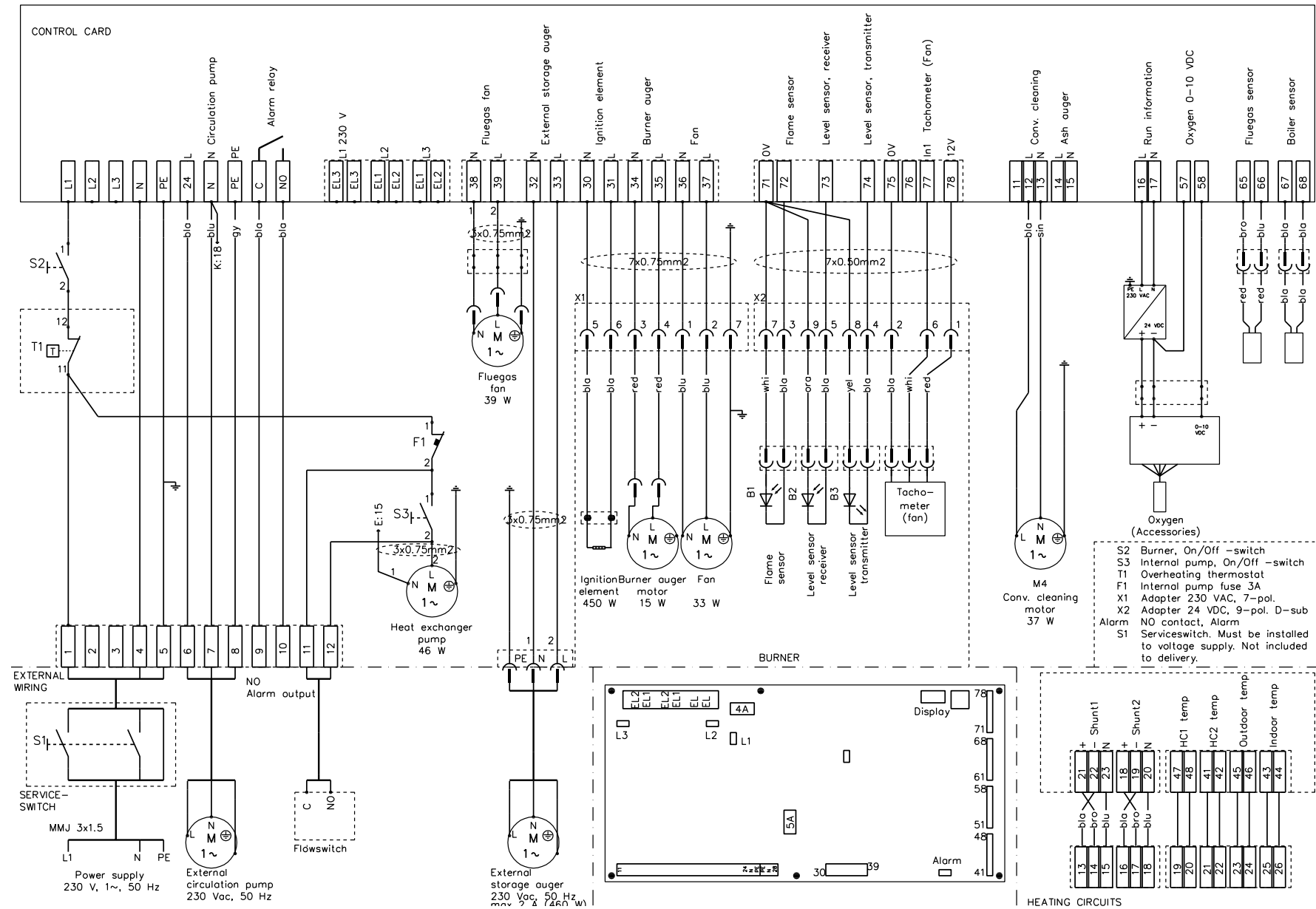

# WIRING DIAGRAM - ULTRA LIGHT

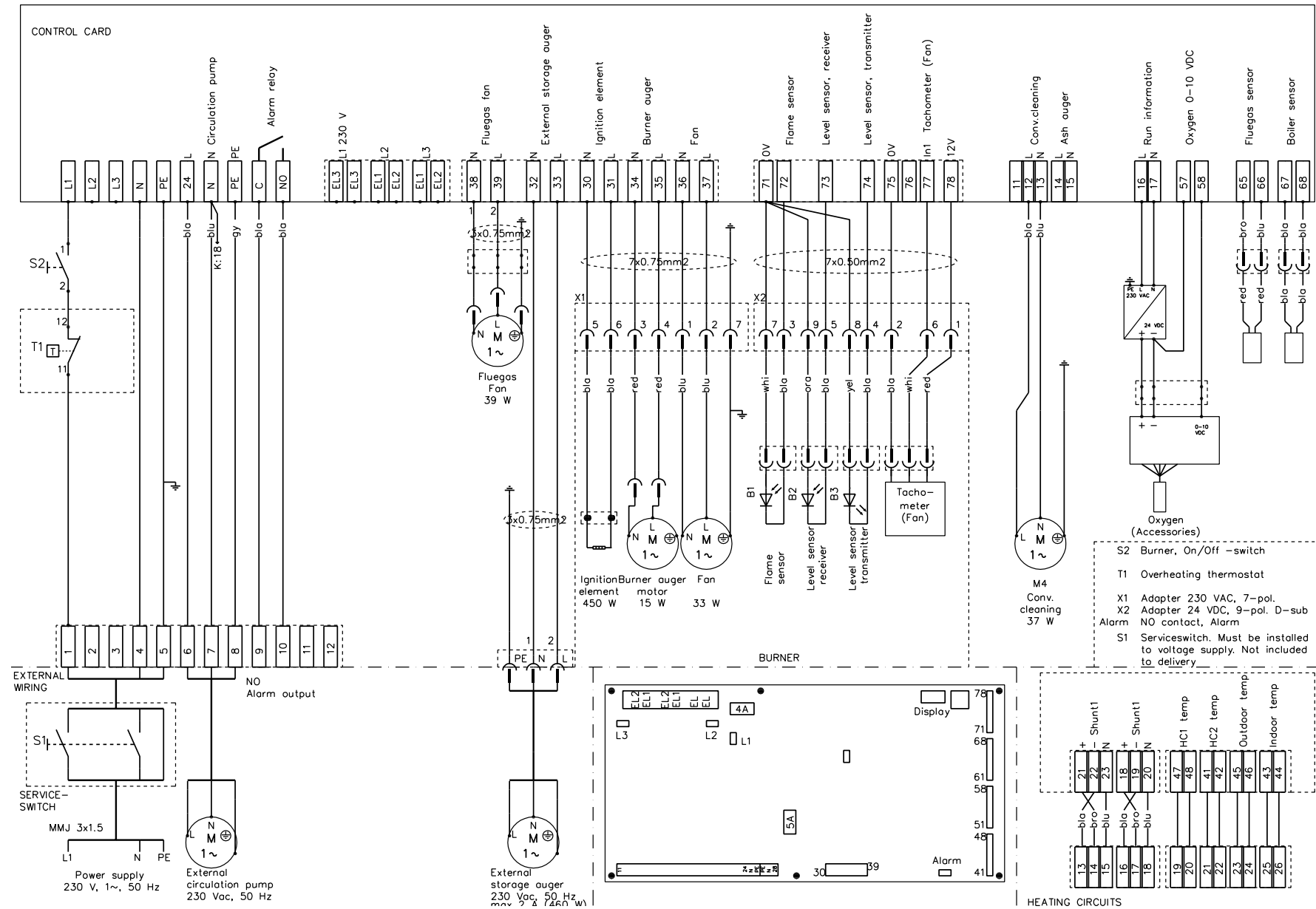

## ■ START-UP AND STOP

### ■ Burner start-up and stop

Turn the burner and the internal pump on from the operating switch. If the flow switch that controls the internal pump is on, set the operating switch to Off mode. The main menu, which shows the temperatures of boiler water and flue gases, will appear on the display. The main menu also shows the Start-up/Stop setting and mode of the burner. If the buttons are not pressed for 10 seconds, a graphic showing temperature and burner data will appear on the display.

The first start-up differs from normal start-up in that there are no pellets in the burner. Likewise, there are no pellets in the external feeding system.

Carry out the following actions in connection with the first start-up or if there are no more pellets in the store:

1. Turn the external auger on from the main menu and wait until pellets arrive at the upper connection of the burner. The external auger will automatically stop after 15 min (the setting can be changed).
2. Set the burner to ON mode.

### ■ Cold start

The burner performs a cold start by means of the ignition resistance when the boiler water temperature is more than 8°C below the set value. The Burner setting shows the message "Start-up 1K", the auger burner turns on and so does the red indicator light. Shortly afterwards, the blower and the ignition resistance turn on. A cold start consists of seven phases (1K-7K). When the flame detection system detects a flame in the burner head, the burner moves directly to phase 5K and the green indicator light turns on. When starting directly from phase 7K, the burner stops for 10 minutes in order for the combustion process to normalise in the burner head. If the flame does not ignite after phase 7K, the burner gives a cold start alarm as described in "Troubleshooting".

Do not change the settings during a cold start. After cleaning the burner head, make sure that the burner performs a cold start because there are no embers in the burner head. The success of the cold start can be ensured by sufficiently increasing the set boiler water temperature and by changing it back to the desired value after ignition.

### ■ Hot start

The burner performs a hot start when the boiler water temperature is within 8°C of the set temperature, for example, after a short power failure. During a hot start, the burner uses the embers in the burner head for ignition and, by doing so, saves energy. In normal use, when the burner goes from Maintain mode to Power mode, the burner performs a hot start. The burner starts up automatically after power failures (hot or cold start depending on the temperature of boiler water).

### ■ Power mode - Maintain mode

After ignition, the burner starts using the Max power range. When the boiler water temperature rises to within 4 °C of its set value, the burner starts using the Mean power range and will continue to use it until the set value is reached. When the target boiler water temperature is reached, the burner blower still runs for one minute before the burner moves to Maintain mode (heating method off). While the burner is in Maintain mode, the auger burner brings pellets to the burner head every now and then in order to maintain the embers.

### ■ Stop

The burner can be stopped at any stage of the combustion process. Set Burner to Off in the main menu. The blower will continue to function for one minute after the burner has been stopped.

## BURNER SETTINGS

The settings for combustion and burner operation can be found in the Power menu.

### Combustion adjustment

In most cases, the factory settings are sufficient for proper and efficient combustion. In addition, they can be applied when the vacuum in the flue pipe unit is about 18-25 Pa and the pellets used have a diameter of 8 mm. In connection with commissioning, it is recommended that the values be adjusted by a skilled installer by means of a flue gas analyser. Carbon monoxide (CO) should be less than 200 ppm and excess air ( $O_2$ ) 6.5-8%.

If combustion is poor, the smoke coming from the chimney is black or if the ash produced is granular, adjust the ratio of fuel to air from the Power menu. Pellet feeding to the burner head can be adjusted through the High auger and Mean Auger settings. The amount of air required for combustion can be adjusted through the Max Blower and Mean Blower settings. The Min settings are not available.

### Adjustment example - External auger operating time

The level switches located in the upper connection of the burner measure the amount of pellet fuel in the burner and control the external storage auger. When the pellet surface drops below the level switches, the external auger activates (factory setting 30 s). The operating time of the external auger should be long enough for the pellet surface to rise to the level of the burner upper connection. Time can be adjusted from Auger External in the Power menu. If the time is too long, the pellets rise to the drop pipe level. In this case, pellets may accumulate in the pipe, which would cause the Pellet Shortage alarm to be given. If the time is too short, there is not enough time to bring pellets. As a consequence, the same alarm may be given.

## BURNER PARTS

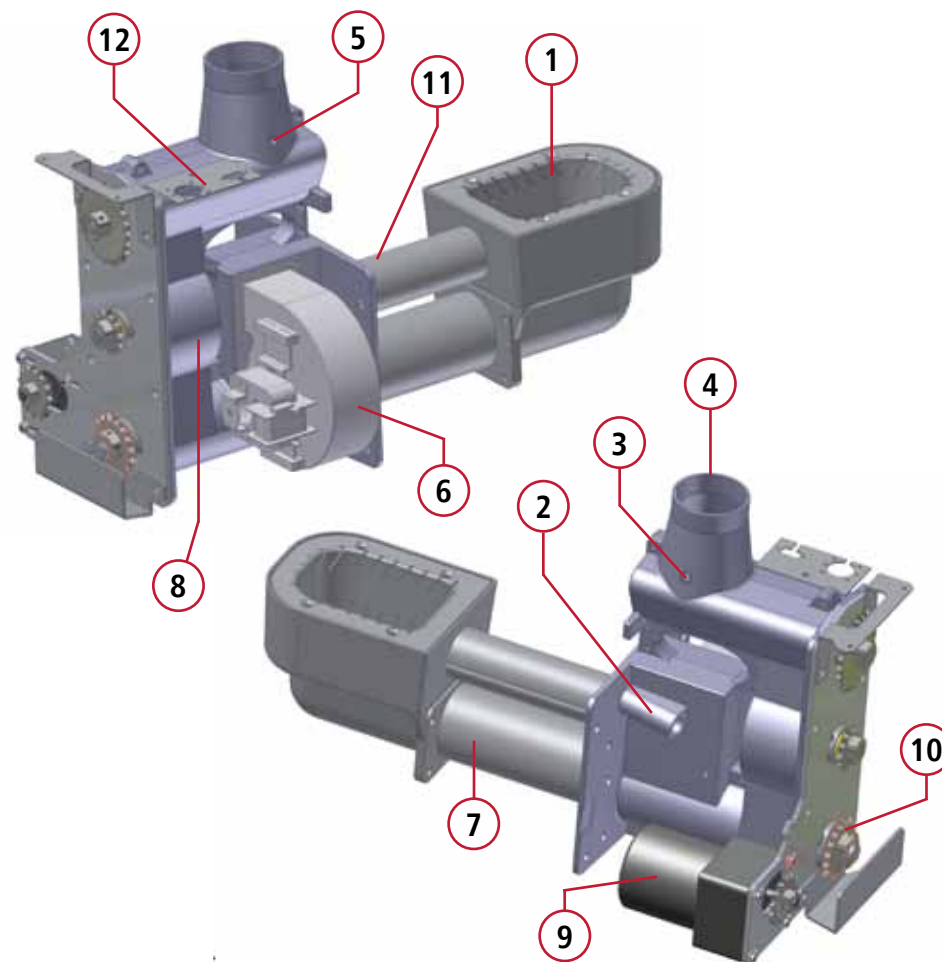

- |                              |  |
|------------------------------|--|
| 1. Combustion vessel         | 7. Auger burner                          |
| 2. Flame detection system    | 8. Blocking feeder                       |
| 3. Level switch, receiver    | 9. Drive motor                           |
| 4. Upper connection          | 10. Wheels and chain (not in the figure) |
| 5. Level switch, transmitter | 11. Primary air pipe                     |
| 6. Blower                    | 12. Connector panel                      |

# MENU STRUCTURE

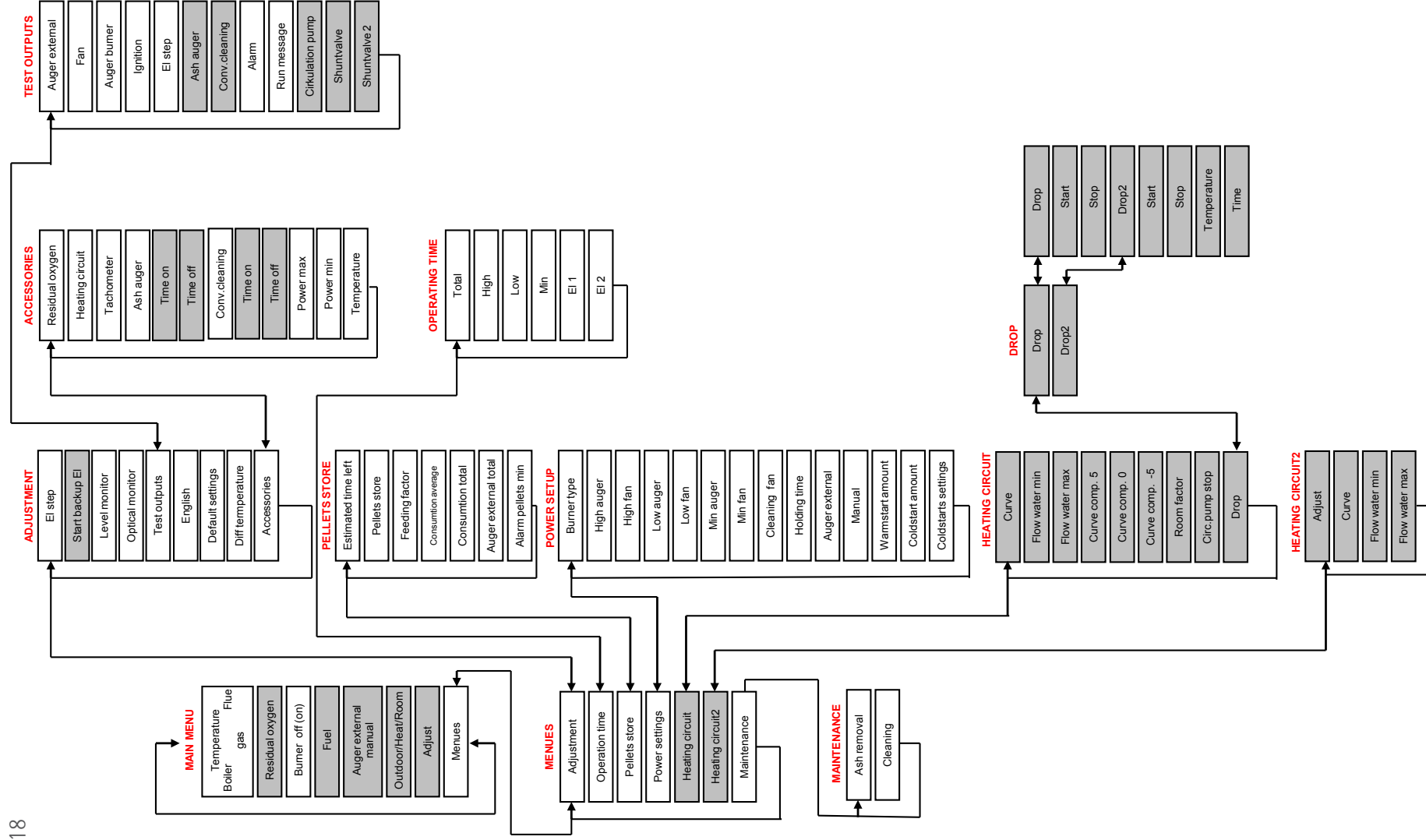

- Showing only when accessories are choiced in meny

- Showing all the time

V091118

## ■ MENU STRUCTURE

The following tables give an overview of the messages that may appear on the display of the control unit. They also indicate which parameters the user is allowed to change freely and which parameters he/she is allowed to change only if instructed to do so by an authorised installer. NOTE! Part of the menu options are displayed only when they are active.

### ■ Main menu

Menu	Setting	Description
Temperature Boiler xx (80) °C	5-95°C	Boiler temperature, set temperature in brackets.
Flue gas xx (250) °C	120-280°C	Flue gas temperature, alarm limit in brackets.
Burner Off (On) mode	On/Off	Burner start-up and stop. Burner operating mode below.
Residual oxygen x.x%	-	Displays the amount of residual oxygen while the burner is in Maintain mode (Accessory)
Auger, external manual operation Off (On)	On/Off	External auger start-up (visible if the burner is in Off mode). The remaining operating time is shown in brackets.
Heating	Pellets	Heating method selection (visible if burner is in On mode - see "Burner Settings").
Outdoor xx°C / Temperature xx(xx) °C / Room xx(xx) °C	Room 0-30°C	Temperature display of heat regulation circuits (visible if activated from the Accessories menu).
Fine adjustment	0-20 °C	Fine adjustment of heating circuit 1 (visible if activated from the Accessories menu and if the internal sensor is not connected)
Menus	-	Accessing submenus: Burner Adjustments, Operating Time, Pellet Store, Power, Heat Regulation, Service.

### ■ Burner Adjustments menu

Menu	Setting	Description
Electrical resistances	0-3	Activation of electrical resistances 0 = not in use, 1 = 6 kW 3 = 9 kW
Activation difference	10-40 °C	Activation temperature of electrical resistances.
Level switch 99% (50%)	10-90%	Displays the pellet level between the level switches of the burner.
Flame detection 99% (50%)	1-98%	Displays the flame strength. Limit value in brackets.
Testing	-	The burner functions (e.g., auger burner, blower, etc.) can be tested in the menu.
Language Finnish	Suomi, Svenska, English, German, Italiano	Menu language selection
Factory settings v090824	Yes / No	Restores the original factory settings.
Temperature difference No	No, 5-60°C	Burner operating lag time. The burner moves to Maintain mode at the target temperature and restarts when the temperature has decreased by an amount equal to the lag time.
Accessories	-	The menu can be used to take accessories into use.

### ■ Operating Time menu

Text on the display	Setting	Description
Total xx h	-	Burner total operating time in Power mode.
Max xx h	-	Burner operating time at Max power.
Mean xx h	-	Burner operating time at Mean power.
Min xx h	-	Burner operating time at Min power.

## MENU STRUCTURE

### Store menu pellet store and consumption monitoring

Text on the display	Setting	Description
Estimated time xx days	Displays the amount of pellet fuel remaining in the store. A new value can be set in connection with a change in the pellet store.	Displays how many days the pellets in the store will last at the average consumption level in question.
Pellet store x.x t	0.0-25.0 t	Displays the amount of pellet fuel remaining in the store. A new value can be set when reloading the pellet store.
Feeding rate xx kg/h	0-76.0 kg/h	Feeding capacity of the storage auger.
Average consumption kg/day	-	Displays the average consumption during the last 8 days.
Overall consumption x.x t	-	Displays the overall consumption of pellets.
Auger external time	-	Displays the operating time of the external auger
Alarm store min x.x t	0.0-3.0 t	A warning appears on the display when the calculated amount of pellet fuel left in the store is equal to the set minimum level

The feeding rate of the storage auger can be determined, for example, by driving the storage auger for 10 minutes and by measuring the weight of the pellets which arrived at the vessel. Multiplying this by six gives how many kilograms the storage auger brings in an hour (kg/h). The feeding rate may vary according to pellet quality.

The Pellet Store setting is used to determine the amount of pellet fuel in the store. The automatic equipment calculates the consumption of pellets on the basis of the feeding rate and operating time of the external auger. In addition, it estimates whether the amount of pellet fuel will suffice for one day on the basis of average consumption.

The Alarm Store Min setting is used to determine the limit at which a message warning about the termination of pellets appears on the burner screen.

### Power Adjustment menu

Menu	Setting	Description
Burner type 20 kW	12/15/20/25/30 kW	Burner type selection. Select your own burner type. Note! Restore the factory values also for the settings related to heat regulation.
Power Max auger 50% Max blower 40% Mean auger 50% Mean blower 40% Min auger 0% Min blower 0%	0-100% 0-100% 0-100% 0-100% 0-100% 0-100%	Auger burner operating cycle at Max power. Blower power at Max power Auger burner operating cycle at Mean power Blower power at Mean power Auger burner operating cycle at Min power. Blower power at Min power
Cleaning blow 2/h	Off, 2/h, 1/h, 1/2h, 1/3h	In Power mode, the blower goes to 100% power and keeps the air vents clean.
Ember maintenance 60 min	No, 0-120 min	Time between ember maintenance cycles. The auger burner carries out a 1-minute feeding cycle while the burner is in Maintain mode. No = The burner does not maintain the embers. In this case, the burner always performs a cold start when starting up. To be used, for example, with an accumulator.
Auger, external 30 s	0-250 s	Operating time of the external auger when the level switches ask for pellets (see "Adjustment Example").
Manual operation 15 min	0-60 min	Operating time of the external auger during manual operation (the burner must be in Off mode, start-up from the main menu)
Hot starts	0-	Number of hot starts
Cold starts	0-	Number of cold starts
Cold start settings	0-99	

### Service menu

Menu	Setting	Description
Alarm Ash removal x (100) h	0-250 h	Gives an alarm indicating that the ash box must be emptied (calculated from the operating time of the external auger). To be determined on the basis of experience.
Cleaning x (100) h	0-250 h	Gives an alarm indicating that the boiler and burner head must be cleaned. To be determined on the basis of experience.

## MENU STRUCTURE

### Accessories menu

Menu	Setting	Description
Residual oxygen	On/Off	Blower power adjustment according to residual oxygen. The oxygen value can be seen in the main menu when the burner is in Power mode.
Heat regulation	On/Off	Heat regulation of two heating circuits possible.
Tachometer	On/Off	Burner operation monitoring
Ash auger Time On Time Off	On/Off 0-10 min 0-250 h	Ash auger activation and operating time determination.
Convection cleaning Time On Time Off	On/Off 1 min (0-10 min) 4 h (0-250 h)	Commissioning of the automatic convection cleaning system and determination of operating times. See page 20.
Power Max	40 % (0-100 %)	Flue gas exhauster power in Power mode.
Power Min	0 % (0-30 %)	Flue gas fan power in Maintain mode.

### Residual oxygen

The value of the residual oxygen measurement can be seen in the main menu when the burner is in Power mode. The measurement is not available in Maintain mode. This saves energy and the sensor. Adjust first the power of the blower so that the oxygen value is between 7% and 8%. The cycle in Power mode should be as long as possible in order for the combustion session to normalise. Then, set the Residual Oxygen setting to On mode from the Accessories menu. After this, if the residual oxygen level becomes too low, the burner will automatically increase the blower power in order for combustion to remain good. The residual oxygen measurement gives an alarm when the value becomes too low.

### Tachometer

The tachometer measures/checks the blower rotation speed, which can also be seen in a graphic on the screen. If the blower is blocked or broken, the tachometer detects the fault and stops the burner.

### Flue gas exhauster

The boiler is equipped with a flue gas exhauster. The exhauster power can be set to Power mode or Maintain mode. The setting can be made in the Accessories menu (Power Max and Power Min).

### Automatic convection cleaning system

The automatic convection cleaning system reduces the amount of cleaning needed by the boiler (NOTE! See page 20). The operating time and pause time for cleaning are determined as needed.

### Heat regulation

The standard equipment of the Ariterm Biomatic+ pellet boiler includes a heat regulator that can be used to control at most two heating circuits. A temperature graph for supply water temperature adjustments can be created for each circuit. Heating circuit 1 can be fine-adjusted by means of the indoor temperature sensor. In addition, the automatic equipment contains a circulation pump control outlet that depends on outdoor temperature. Standard delivery includes the control kit for heating circuit 1, the shunt motor/valve and the temperature sensors (supply water, outdoor and indoor temperature).

### Electrical installations

The terminal blocks for shunt motors and temperature sensors are under the front panel. The same applies to the circulation pump control. The connection must be carried out according to the connection diagram. NOTE! It is recommended to keep the wires of the temperature sensors separate from the feeding cables. Use the lead-ins on the right-hand side of the boiler roof for the temperature sensors. The wires of the temperature sensors should be kept as short as possible. NOTE! If the outdoor temperature sensor is detached or broken, the outdoor temperature is 0 °C by default.

In connection with floor heating, it is important to determine the supply water min and max values for the temperature graph. With parquet floor, the supply water temperature should not rise above 45°C. In these cases, it is recommended to install a thermostat for the circulation pump control. The thermostat switches the pump control off if the supply water temperature rises above 45°C. If the supply water temperature is too high, this may damage parquet floor.

### General information

The temperature graph determines the supply water temperature according to the outdoor temperature. The colder it is outside, the warmer the supply water. However, in connection with radiator heating, the supply water temperature increases exponentially when the outdoor temperature decreases. With a correct temperature graph, the room temperature is pleasant regardless of the temperature outside.

Stone floors may feel cold in summer. In this case, the supply water temperature can be set to at least 22-25 °C to keep the floor pleasantly warm. In this situation, take into account the Circulation Pump Stop setting. Heating circuit 1 may also be equipped with an indoor temperature sensor. The indoor temperature can be set to a certain value. The temperature graph can be fine-adjusted in order to reach this value. The room coefficient can be used to determine the supply water correction coefficient in order for the indoor temperature to reach the set value. The factory setting is 5°C. In other words, if the indoor temperature is 19 (20)°C, the supply water temperature increases by 5°C in order for the set indoor temperature to be achieved. The room coefficient depends on insulation level and heating system.

## HEATING CIRCUIT SETTINGS

### Heat Regulation menu

Menu	Setting	Description
Graph	22-56 °C	Temperature graph determination (outdoor temperature 0 °C)
Supply water min	0-30 °C	Supply water minimum temperature
Supply water max	30-85 °C	Supply water maximum temperature
Compensated graph +5 °C	0-5 °C	Heating circuit graph compensation with an outdoor temperature of +5 °C
Compensated graph 0°C	0-5 °C	Heating circuit graph compensation with an outdoor temperature of 0 °C
Compensated graph -5°C	0-5 °C	Heating circuit graph compensation with an outdoor temperature of -5 °C
Room coefficient	0-10 °C	Influence coefficient of the indoor temperature difference on water supply.
Circulation pump stop	Off, 0-40 °C	Outdoor temperature at which the circulation pump is stopped.
Drop	-	Drop menu of the heating circuits

### Heating circuit 1 settings

The Heating Circuit 1 Fine Adjustment setting is visible in the main menu if the indoor temperature sensor is not connected. Fine adjustment can be used to raise or lower the entire graph in the vertical direction (parallel transfer).

NOTE! The Heat Regulation 2 menu appears when supply water sensor 2 is connected. The compensations and drops specified for heating circuit 1 also apply to heating circuit 2.

### Heating circuit 1 settings

The temperature graph can be determined by means of the Graph setting (possible values 22-56 °C).

Heating circuit 1 settings	
Graph = 40 °C, Supply water Min = 10 °C, Supply water Max = 80 °C	
Outdoor temperature 0 °C	Supply water 40 °C
Outdoor temperature -20 °C	Supply water 55 °C
Outdoor temperature +20 °C	Supply water 10 °C

Example 1.

## HEATING CIRCUIT SETTINGS

The graph curves more quickly when the outdoor temperature is above +16 °C. The Supply Water Max and Min settings can be used to cut the top and bottom of the graph. The angular coefficient of the graph slightly increases when the Graph setting is increased.

### Temperature graph compensation

The graph can be compensated when the outdoor temperature is -5 °C, 0 °C and +5 °C. In this case, the air may be breezy and humid. If so, the temperature graph might have to be changed. Compensation also affects the temperature graph of heating circuit 2 in the same way.

### Circulation pump control

The Circulation Pump Stop function can be used to determine the outdoor temperature at which the pump stops. The pump turns on again once the outdoor temperature has decreased by 3 °C. However, the circulation pump runs 1 min a day if the outdoor temperature remains above the set value.

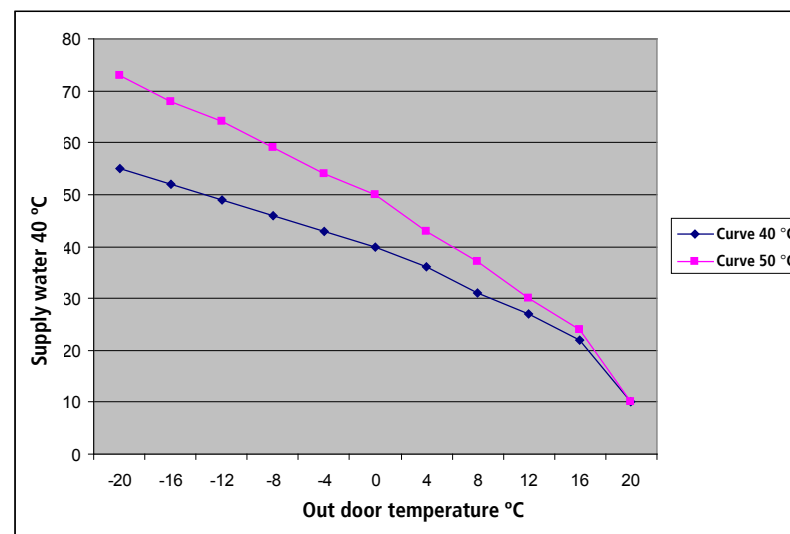

## HEAT REGULATION EXAMPLES

The following section contains examples of the different heating systems and their settings. The settings are indicative and fine adjustment might be required.

Menu	Floor heating system	Radiator heating system (well-insulated building)	Radiator heating system (normally insulated building)
Graph	28 °C	40 °C	50 °C
Supply water min	20 °C	17 °C	17 °C
Supply water max	40 °C	70 °C	80 °C
Compensated graph	+5 °C = 0 °C	+5 °C = 0 °C	+5 °C = 0 °C
Compensated graph	0 °C = 0 °C	0 °C = 0 °C	0 °C = 0 °C
Compensated graph	-5 °C = 0 °C	5 °C = 0 °C	5 °C = 0 °C
Room coefficient	2 °C	4 °C	4 °C
Circulation pump stop	20 °C	20 °C	20 °C

### Floor heating system

A thermostat is installed in the circulation pump control of the heating circuit. The thermostat switches the pump control off if the supply water temperature rises above 45 °C. If the supply water temperature is too high, this may damage parquet floor.

If, when the outdoor temperature is below 0 °C, the room temperature is too low, slightly increase the Graph setting. Correspondingly, if the room temperature is too high, decrease the setting. In summer, the Supply Water Min setting can be used to ensure a comfortable floor temperature.

If the room temperature feels too high or too low while the outdoor temperature is between -5 °C and +5 °C, the shape of the graph can be modified through the Compensated Graph settings. The settings can be used to increase/decrease the supply water temperature.

If an indoor temperature sensor has been installed, the sensor automatically corrects the supply water temperature to obtain the desired indoor temperature. The room coefficient is used to determine how many degrees the supply water temperature must decrease in order for the room temperature to increase by 1 °C.

## HEAT REGULATION MENU STRUCTURE

### Drop menu

Menu	Setting	Description
<b>Drop</b>	Off, 1-5, 1-7, 6-7	Days when drops are to be carried out. 1-5 = Mon-Fri, 1-7 = Mon-Sun and 6-7 = Sat-Sun
Start	00.00 - 24.00	Time at which the drop starts
End	00.00 - 24.00	Time at which the drop ends
<b>Drop 2</b>	Off, 1-5, 1-7, 6-7	Days when drops are to be carried out. 1-5 = Mon-Fri, 1-7 = Mon-Sun and 6-7 = Sat-Sun
Start	00.00 - 24.00	Time at which the drop starts
End	00.00 - 24.00	Time at which the drop ends
<b>Temperature</b>	0-30°C	Temperature of the drop
<b>Time</b>	0-23 h and 0-59 min	Time determination

The Drop menu can be used to determine the two times when the supply water temperature is decreased by a set value. Set first the right time so that the drops are carried out at the right time. For example, the setting 1-5 means the time between Monday and Friday.

### Heat Regulation 2 menu

Menu	Setting	Description
<b>Fine adjustment</b>	-40 - +20 °C	Parallel transfer of the temperature graph
<b>Graph</b>	23-56 °C	Temperature graph determination (outdoor temperature 0 °C)
<b>Supply water min</b>	10-50 °C	Supply water minimum temperature
<b>Supply water max</b>	30-80 °C	Supply water maximum temperature

## ALARMS AND TROUBLESHOOTING

In case an alarm becomes active, this is indicated by the burner on the display of the control panel with a red light and a text message. This facilitates troubleshooting, because the user can see the cause of the problem. The burner stops in connection with an alarm. The cause of the fault must be determined before switching the device on again. If an alarm is given often, this may be due to incorrect adjustments/settings. When the red light blinks, the burner display shows a warning message, for example, about the fact that it is time to empty the ash box. However, the burner functions normally. Acknowledge by pressing the C button. In order to check and service the burner, it is first necessary to cut the voltage supply and detach the burner connection wires before removing the burner from the boiler. After this, the burner cover can be detached and the inspection of the flame detection sensor or other component can be carried out.

Alarm message / Cause	Check	Procedure
<p>The burner has stopped and the display is dark.</p> <p>Voltage is no longer supplied to the burner.</p>	<ol style="list-style-type: none"> <li>1. Burner overheat protection.</li> <li>2. Voltage supply fuse.</li> <li>3. Glass tube fuses of the burner card and connection of the display panel.</li> </ol>	<ol style="list-style-type: none"> <li>1. Find out the cause of overheating and confirm receipt of the overheat protection.</li> <li>2. Change the fuse. If the fuse continues to blow, contact an electrician.</li> <li>3. The inspection may be carried out by an electrician. Take out the display panel and check the glass tube fuses of the controller card. Check the display panel connection.</li> </ol>
<p><b>Alarm cold start</b></p> <p>The flame detection sensor has not detected any flames in connection with a cold start. The alarm is given 10 min after the end of the cold start.</p>	<ol style="list-style-type: none"> <li>1. Are there pellets in the burner head?</li> <li>2. Operation and cleanliness of the flame detection sensor</li> <li>3. Ignition resistance</li> </ol>	<ol style="list-style-type: none"> <li>1. If the burner head does not contain pellets but the upper connection of the burner does, try to reignite. Make sure that the burner head receives pellets.</li> <li>2. The operation of the flame detection sensor can be checked by reflecting light on it. How the sensor reacts to it can be followed from the Burner Adjustments menu. The flame detection sensor may have become dirty due to weak draught. This prevents the sensor from recognising flames. See "Inspection and Maintenance".</li> <li>3. Go to the Testing menu and turn the blower and the ignition resistance on. Make sure that the resistance heats up and ignites the pellets.</li> </ol>

Alarm message / Cause	Check	Procedure
<p><b>Alarm flame detection</b></p> <p>The flame detection sensor has not detected any flames for 10 minutes with the burner in Power mode. The level switches have requested more pellets, which means that pellets have arrived at the burner head.</p>	<ol style="list-style-type: none"> <li>1. Operation and cleanliness of the flame detection sensor.</li> <li>2. Blower operation</li> </ol>	<ol style="list-style-type: none"> <li>1. See "Alarm cold start" (paragraph 2).</li> <li>2. Go to the Testing menu and turn the blower on. Make sure that the blower works.</li> </ol> <p>If the flame detection sensor becomes often sooty or overheated, this may be due to faulty adjustments or insufficient vacuum in the furnace. In these cases, contact the installer.</p>
<p><b>Alarm hot start</b></p> <p>After a hot start, the flame detection sensor has not detected any flames for 10 minutes. The embers have all burnt and the burner does not use any ignition resistance when performing a hot start. After cleaning the burner head, the boiler water temperature may be within 8°C of the set temperature. In this case, the burner will try to perform a hot start. Since there are no embers, the alarm will be given.</p>	<ol style="list-style-type: none"> <li>1. Operation and cleanliness of the flame detection sensor.</li> <li>2. Ember maintenance time (Power menu)</li> </ol>	<ol style="list-style-type: none"> <li>1. Check the flame detection system as specified above.</li> <li>2. Check the embers while being in Maintain mode. Excessive draught may burn the embers completely. In this case, reduce the draught and the time of the Ember Maintenance setting.</li> </ol> <p>If the alarm has been given after cleaning the burner head, increase the set temperature of boiler water temporarily in order for the burner to be able to perform a cold start.</p>
<p><b>Alarm residual oxygen</b></p> <p>Residual oxygen has been under 4.5% for 2 min, which has caused poor combustion. The automatic power increase of the blower has not been enough.</p>	<ol style="list-style-type: none"> <li>1. Are the air vents of the burner head open?</li> <li>2. Is the blower functioning well? Has the blower been correctly adjusted?</li> </ol>	<ol style="list-style-type: none"> <li>1. Clean the burner head and open the air vents.</li> <li>2. Check the operation and power of the blower.</li> </ol> <p>NOTE! If residual oxygen is set to Off mode, no alarm is given even if the residual oxygen value is displayed on the screen.</p>

## ALARMS AND TROUBLESHOOTING

Alarm message / Cause	Check that	Procedure
<p><b>Alarm pellet shortage</b></p> <p>The level switches have not detected pellets in the burner upper connection even if the external auger has run for four times its operating time.</p>	<ol style="list-style-type: none"> <li>there are pellets in the store.</li> <li>pellets have not accumulated in the drop pipe.</li> <li>the level switches function well.</li> <li>the inclination of the drop pipe is not too steep (over 45°) or too gentle.</li> <li>the motor shaft rotates the auger and the external auger motor functions well.</li> </ol>	<ol style="list-style-type: none"> <li>Add pellets and drive the external auger until the pellets arrive at the upper connection of the burner. Perform start-up.</li> <li>Adjust the operating time of the external auger according to the adjustment example</li> <li>Check the operation of the level switches from the Burner Adjustments menu. The value should decrease below the one in brackets. After this, the external auger should turn on. When the auger stops, the value should be 99%.</li> </ol>
<p><b>Alarm blockage</b></p> <p>The flame detection system has not detected any flames for 10 minutes and the level switch has not asked for more pellets. In other words, the burner head has run out of pellets and the flame has gone out.</p>	<ol style="list-style-type: none"> <li>the level switch eyes are clean (dust).</li> <li>the level switch functions correctly.</li> <li>the burner wheel is fastened and the chain is in good state.</li> <li>pellets arrive at the combustion vessel.</li> <li>the flame detection sensor functions well.</li> <li>the feeding auger, blocking feeder and auger burner rotate and are not blocked due, for example, to a foreign object.</li> </ol>	<p>If there is no fuel in the upper connection of the burner, check the cable connections of the level switches. If this does not help, wipe the level switches clean. If the external feed of the burner does not start in spite of this or the level switches must be cleaned all the time, they may be defective and the installer should have a look at them.</p> <p>A possible foreign object in the pellet fuel must be removed if it gets stuck in the blocking feeder or in one of the feeding augers. Remove the upper connection and take out the possible foreign object from the feeding auger or blocking feeder.</p>

Alarm message / Cause	Check that	Procedure
<p><b>Alarm heat sensor</b></p> <p>The boiler water temperature sensor is detached</p>	the boiler sensor is in place and the wires are intact.	If the boiler sensor wire is not connected or is broken, the sensor shows the reading 0°C and the alarm is activated.
<p><b>Alarm max flue gas</b></p> <p>The flue gas temperature has exceeded the alarm limit.</p>	<ol style="list-style-type: none"> <li>the bypass damper of the boiler is in place.</li> <li>the flue gas sensor is in the flue gas channel.</li> </ol>	<ol style="list-style-type: none"> <li>Put the bypass damper in place</li> <li>Place the flue gas sensor in the flue gas channel.</li> </ol>
<p><b>Alarm electronics</b></p> <p>The burner electronics have overheated (50 °C).</p>	the boiler room temperature is correct.	Make sure that there is enough insulation in order for the boiler room temperature to remain below 50°C.
<p><b>Alarm overheat</b></p> <p>The boiler water temperature sensor shows more than 99 °C.</p>	<ol style="list-style-type: none"> <li>the circulation pump is on</li> <li>the set boiler water temperature</li> </ol>	<ol style="list-style-type: none"> <li>Switch the circulation pump on.</li> <li>The maximum set temperature for boiler water is 95°C. However, the temperature may rise above this limit due to residual heat. In this case, decrease the setting.</li> </ol> <p>The cause of overheating must be found out before restarting.</p>
<p><b>Alarm tachometer</b></p> <p>The blower is not rotating</p>	1. The blower is rotating	The tachometer monitors the operation of the blower. If it detects that the blower is not rotating, an alarm is given and the burner stops. However, if the blower is functioning, the fault may be in the tachometer. The tachometer can be switched off from the Accessories menu.
<p><b>Alarm cleaning</b></p>	The burner gives a warning when it is time to clean the burner head. The time is calculated on the basis of the operating time of the auger burner. The interval can be set in the Service menu. The setting 0 means that the function is off.	
<p><b>Alarm ash removal</b></p>	The burner gives a warning when it is time to empty the ash box. The time is calculated on the basis of the operating time of the auger burner. The interval can be set in the Service menu. The setting 0 means that the function is off.	

## ■ GUARANTEE AND DECOMMISSIONING

### ■ Guarantee

For Warranty Issues Ariterm Sweden AB refers to our local Distributor.

### ■ Decommissioning

An end-of-life boiler is suitable for scrapping. Its plastic parts are landfill waste.

## ■ MOST COMMON SPARE PARTS

Product no.	Description
	Overheat protection TG400
	Gasket 2x183x200, burner
	Grundfos UPS 25-40 pump (not Ultra Light)
	Boiler temperature sensor
	Flue gas temperature sensor
	BeQuem 20 inner cage
	Display card BM+/-BQ
	ESBE ARA661 shunt motor
	Sweeping motor SPG TS09-0175
	Controller card Biomatic+
	Outdoor temperature sensor
	Indoor temperature sensor
	Supply water sensor
	Chain wheel Z=12
	Hub chain wheel Z=15
	Hub chain wheel Z=24
	47-link chain
	Chain shackle
	Feed motor SPG S8115GXCE/S8KA180M
	Internal casting of the burner head
	Internal casting of the burner head
	Blocking feeder
	Auger burner
	Blower SUO78613
	Ignition resistance 450W
	Level switches (incl. transmitter and receiver)
	Optical flame switch

## ■ SERVICE AND MAINTENANCE

The boiler and burner will function without problems for a long time if the following instructions are observed:

- The boiler must be kept in a dry environment
- The boiler and burner operate all the time within the defined adjustment values.
- Clean the boiler when the temperature of flue gases has increased by 20-30°C with respect to the temperature they have with a clean boiler.
- Check the burner head and clean it as needed. Remove the sintering and, if necessary, scrape the air gaps open.
- Replace the damaged part with a new one in due time
- Check to make sure that no condensed water or water coming from pipe leaks can damage the boiler.

**Note! Always disconnect the main power before maintenance work!**

### ■ Boiler cleaning

Turn the burner off for about an hour before maintenance work and cut the main power. Clean the furnace from the burner opening and the convection part from the cleanout hatch on the top of the boiler. Clean all convection pipes with the cleaning brush delivered with the boiler (see the next page). Finally, empty the ash box. The ash from the ash box can be used to determine whether combustion has been good. The ash should be powdery.

The interval for ash removal and boiler cleaning can be specified in the Service menu on the basis of experience. The boiler should be cleaned when the temperature of flue gases rises by 20°C with respect to the temperature they have with a clean boiler.

### ■ Burner cleaning

Turn the burner off for about an hour before maintenance work and cut the main power. Pull the burner out of the boiler, check the burner head and carry out the necessary operations. The burner head does not usually need special maintenance. However, in connection with ash removal, it is good to check whether hardened ash has accumulated in the burner head. To detach the hardened ash, use a screwdriver or similar tool. At the same time, check whether ash has flown to the mouth of the flame detection pipe and clean it as needed.

In connection with a new fuel delivery, the burner head must be checked in order to detect possible sintering (mutually bound ash, rock and gravel-like particles in the burner head) over time. Such particles must absolutely be removed from the burner head at short intervals so that the primary ring will not become overheated and get damaged.

Sintering is often due to impurities in the fuel. If this is the case, you should immediately file a complaint with the fuel supplier. Pay special attention to pellet quality when you receive a new delivery or when you change suppliers.

### ■ Check every 1-2 years

Unfasten the burner primary air ring, which is fastened by means of four screws and nuts. Clean the air vents of the primary ring and remove all ash. At the same time, check the primary air pipe and clean it of ash.

Detach the protective casing of the burner. Check the chain wheels and chains for wear or whether the chain has loosened. Adjust and change as needed. Lubricate the chain with thin oil.

### Note!

Always remember to be careful when dealing with ash because it may still be incandescent. The ash must be stored in a fire-resistant vessel.



Burner cleaning is started by unfastening the quick locking clips on both sides of the burner and by pulling the burner out of the boiler.

Make sure that the burner wires do not get damaged.

## BOILER CLEANING

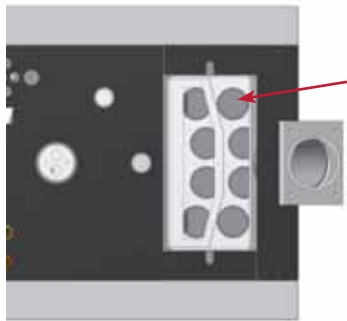

### Automatic convection cleaning system

The boiler is equipped with automatic convection cleaning system that automatically carries out the sweeping at certain intervals. In any case, the convection channels must be cleaned (swept) two times a year. The cleaning is done through the cleanout hatch on the top of the boiler. The automatic sweeping system must be removed before sweeping. Disconnect the main power before maintenance work.

### Other boiler cleaning operations

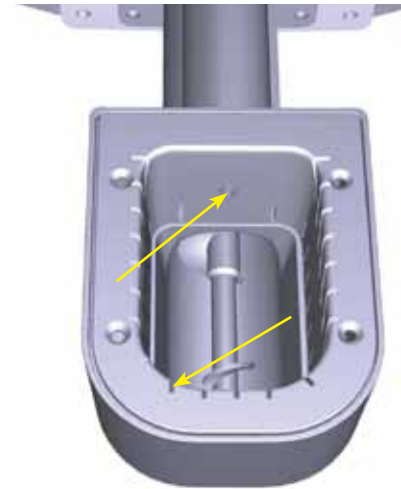
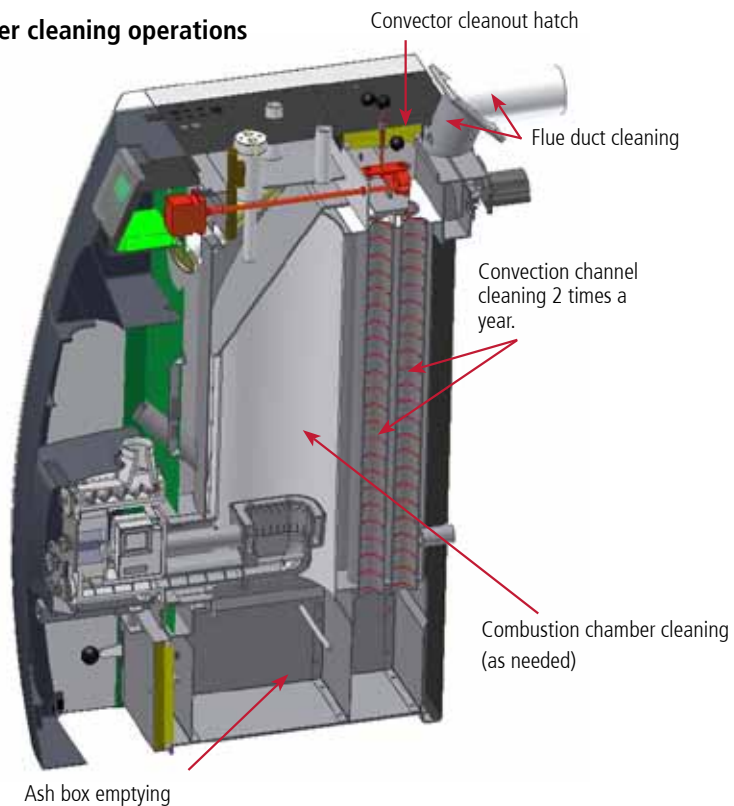

Remove all ash and possible sintering from the combustion vessel. The primary air intakes and the ignition resistance opening must be open.

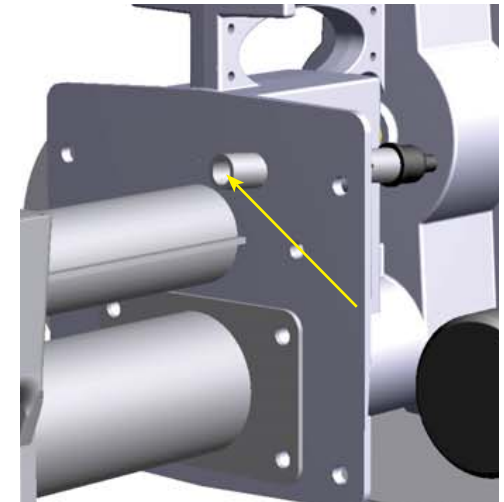

Clean the metal pipe of the flame detector so that the ash accumulated in the pipe will not hinder the operation of the flame detector.

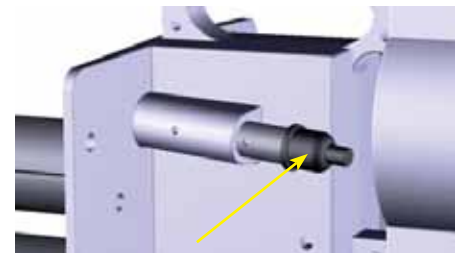

Pull the flame detector out of its pipe with caution and hold on to the rubber lid.



Clean the flame detector of impurities.

### NOTE!

If the protective glass of the flame detector breaks or detaches, the flame detector can no longer be used and must be replaced with a new one.

## ■ WOOD PELLETS AS FUEL

Wood pellets are renewable bioenergy and provide fuel in a compact and uniform form, which is easy to handle. The moisture content is less than 10%, which means that the pellets do not freeze or become mouldy. No chemical substances are used in the manufacturing process. Instead, the binding agent is the tree's own lignin.

The pellet diameter is 6 to 12 mm and the length is 10 to 30 mm. Due to their small size, the pellets move freely in the feeding augers.

### NOTE!

The burner has been adjusted for 8 mm pellets at the factory. If pellets of other sizes are used, the burner must be readjusted..

Most of the disturbances that occur as a result of bad fuel quality are caused by incorrect handling and intermediate storage before the product is delivered to the customer. Large contents of fine materials may be due to insufficient sifting. Ash sintering is often caused by silicate impurities (sand). These materials cannot be detected before burning. NOTE! If the ash is sintered, all sintered material must be continuously removed from the burner head.

### ■ Fuel storage

Thanks to the feeding system, it is possible to build the pellet store for so-called bulk deliveries. The store can be placed either inside or in a separate building outside the house. The shorter the transport distance from the store to the burner, the better the feeding system functions. Fire regulations must be taken into consideration when designing the boiler room and the storage area.

The entire store must be insulated with extreme caution in order to prevent dust from spreading.

The pellet delivery methods must be taken into account when choosing the store size. In general, the pellets can be obtained in small sacks (20 kg), large sacks (500 kg) or directly to the store by means of a blower truck. One tonne of pellet fuel requires about 1.6 m<sup>3</sup> of storage space. The smallest delivery batch for loose pellets is three tonnes. A store of 8 to 10 cubic metres is a reasonable solution for many houses and involves lower delivery costs.

Fuel recommendation	
Raw material	Chemically untreated, barkless wood
Diameter	8 mm
Length	15-32 mm
Volume weight	over 600 kg/m <sup>3</sup>
Moisture content	less than 10%
Ash content	less than 0.7 weight %
Fine material content	max 4 weight %
Ash melting temperature	> 1,100 °C
Energy content	>4.75 kWh/kg

## ■ FEEDING SYSTEM

### ■ Weekly silo PF300

The lightweight silo is an alternative to the self-built silo. The practical PF300 may also be used as intermediate store for pellets. The capacity of the pellet silo is 300 litres and its filling is facilitated by the intermediate grid in the silo. Contrary to the figure, the silo is delivered with a lid.

#### NOTE!

More information on the installation of PS300/Feedo can be found in separate manuals.

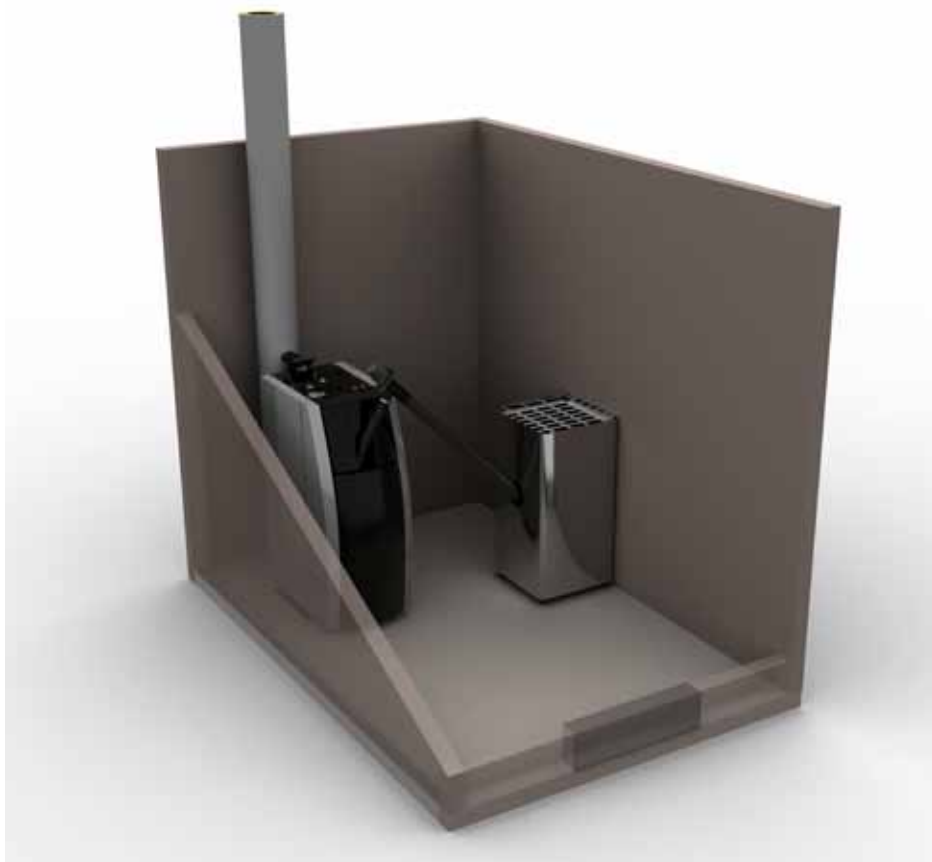

### ■ Depo

Feed chute Depo is a patented pellet transfer system that effectively, reliably and quietly feeds pellets from the silo via the feeding system to the burner.

### ■ Feedo

Feedo is a pellet feeding system designed to work with feed chute Depo.

#### NOTE!

More information on the installation of Depo/Feedo can be found in separate manuals.

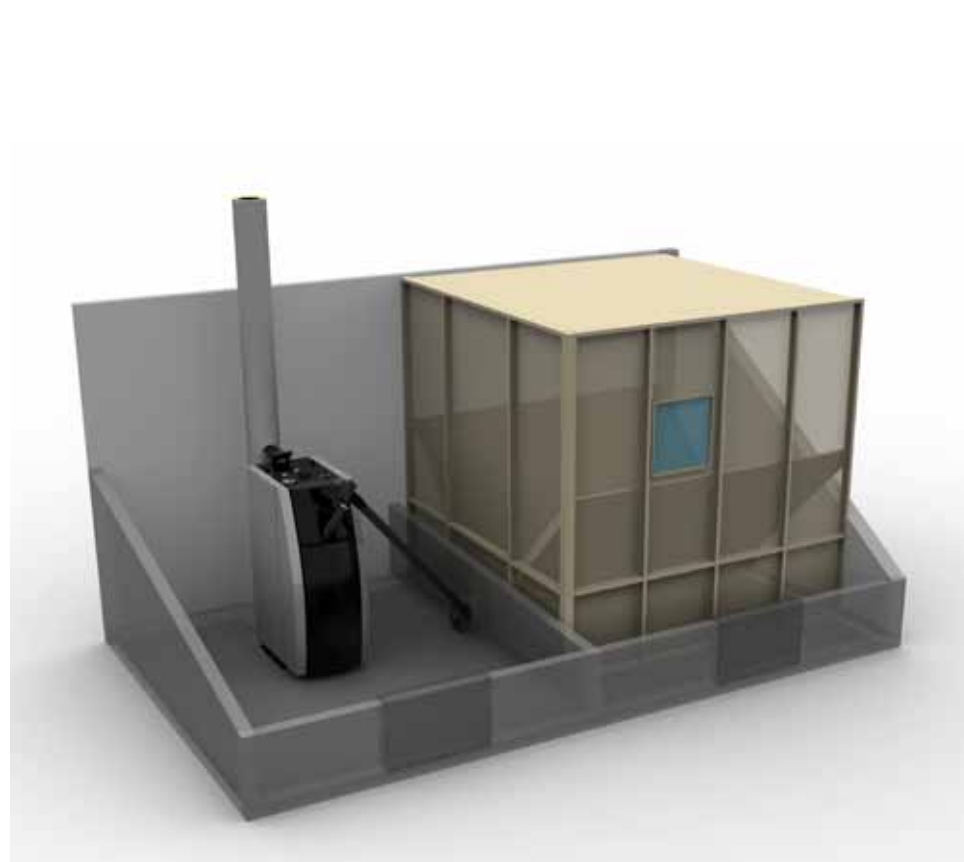

# DECLARATION OF CONFORMITY

ARITERM

## VAATIMUSTENMUKAISUUSVAKUUTUS

Valmistaja: ARITERM OY  
Osoite: PL 59, 43101 SAARJÄRVI  
Laitte: Biomatic+ 20 pelletilämmityskeskus

- Valmistaja vakuuttaa,
- että tämän yksikön kattilaosan valmistuksessa on huomioitu Euroopan yhteisön neuvoston painelaittedirektiivin (97/23/EY) olennaiset turvallisuusvaatimukset. Vaatimustenmukaisuuden arviointimenettelyinä on käytetty H - moduulia. (Ilmoitettu laitos 0424)
  - että polttinosa valmistuksessa on noudatettu oheisten direktiivien vaatimuksia:  
EMC-direktiivi 89/336/EEC, pienjännittdirektiivi 73/23/EEC ja koneidirektiivi 98/37/EC
  - seuraavia standardeja on sovellettu:  
EN 303-5 ( luokka 3 )  
LVD: EN 60335-1  
Konedirektiivi: EN 292-1, EN 292-2  
EMC: EN 55014, EN 61000-3-2, EN 61000-3-3

## DECLARATION OF CONFORMITY - MANUFACTURES DECLARATION

Manufacturer: ARITERM OY  
Address: P.O.BOX 59, FIN-43101 SAARJÄRVI  
Equipment: Biomatic+ 20 pellet heating unit

- Manufacturer assures,
- that in the production of the boiler unit the essential safety requirements of EC council's directive for pressure boilers (97/23/EY) have been complied with. As estimation method of conformity has been used H - module. (Notified body 0424)
  - that in the production of the burner following directives have been applied:  
EMC directive 89/336/EEC, low voltage directive 73/23/EEC and the machine directive 98/37/EC
  - following standards have been applied:  
EN 303-5 ( class 3 )  
LVD: EN 60335-1:2002, EN 50366:2003  
Machine directive: EN ISO 12100-1:2003, EN ISO 12100-2:2003  
EMC: EN 55014-1, EN 61000-3-2, EN 61000-3-3, EN 61000-6-1, EN 61000-6-3

## FÖRSÄKRAN OM ÖVERENSSTÄMMELSE - TILLVERKAREDEKLARATION

Tillverkare: ARITERM OY  
Adress: P.O.BOX 59, FIN-43101 SAARJÄRVI  
Apparat: Biomatic+ 20 pelletsvärmecentral

- Tillverkare försäkrar,
- att vid tillverkningen av denna panna har man iakttagit väsentliga säkerhetskrav av EG rådets direktiv för tryckkärl (97/23/EY). Som värderingsmetod av överensstämmelse har använts H - modul. (notified body 0424)
  - att vid tillverkningen av brännaren har man iakttagit följande direktiven:  
EMC direktivet 89/336/EEC, lågsämningsdirektivet 73/23/EEC samt maskindirektivet 98/37/EC
  - följande harmoniserade standarder har tillämpas:  
EN 303-5 ( klass 3 )  
LVD: EN 60335-1:2002, EN 50366:2003  
Maskindirektiv: EN ISO 12100-1:2003, EN ISO 12100-2:2003  
EMC: EN 55014-1, EN 61000-3-2, EN 61000-3-3, EN 61000-6-1, EN 61000-6-3

Arterm Oy  
  
Karl Väliaho  
Toimitusjohtaja  
Managing director  
Verkställande direktör

ARITERM

## VAATIMUSTENMUKAISUUSVAKUUTUS

Valmistaja: ARITERM OY  
Osoite: PL 59, 43101 SAARJÄRVI  
Laitte: Biomatic+ 30 pelletilämmityskeskus

- Valmistaja vakuuttaa,
- että tämän yksikön kattilaosan valmistuksessa on huomioitu Euroopan yhteisön neuvoston painelaittedirektiivin (97/23/EY) olennaiset turvallisuusvaatimukset. Vaatimustenmukaisuuden arviointimenettelyinä on käytetty H - moduulia. (Ilmoitettu laitos 0424)
  - että polttinosa valmistuksessa on noudatettu oheisten direktiivien vaatimuksia:  
EMC-direktiivi 89/336/EEC ja koneidirektiivi 98/37/EC
  - seuraavia standardeja on sovellettu:  
EN 303-5 ( luokka 3 )  
Konedirektiivi: EN 292-1, EN 292-2  
EMC: EN 61000-6-3:2001, EN 55014-1:2001+A1:2001, EN 55011B, EN 55014, EN 61000-3-2:2001, EN 61000-3-3:1995, A1:2001, EN 55014-2:1997+A1:2002, EN 61000-6-2:2001, EN 61000-4-2, -3, -4, -5, -6, -11.

## DECLARATION OF CONFORMITY - MANUFACTURES DECLARATION

Manufacturer: ARITERM OY  
Address: P.O.BOX 59, FIN-43101 SAARJÄRVI  
Equipment: Biomatic+ 30 pellet heating unit

- Manufacturer assures,
- that in the production of the boiler unit the essential safety requirements of EC council's directive for pressure boilers (97/23/EY) have been complied with. As estimation method of conformity has been used H - module. (Notified body 0424)
  - that in the production of the burner following directives have been applied:  
EMC directive 89/336/EEC and the machine directive 98/37/EC
  - following standards have been applied:  
EN 303-5 ( class 3 )  
Machine directive: EN 292-1, EN 292-2  
EMC: EN 61000-6-3:2001, EN 55014-1:2001+A1:2001, EN 55011B, EN 55014, EN 61000-3-2:2001, EN 61000-3-3:1995, A1:2001, EN 55014-2:1997+A1:2002, EN 61000-6-2:2001, EN 61000-4-2, -3, -4, -5, -6, -11.

## FÖRSÄKRAN OM ÖVERENSSTÄMMELSE - TILLVERKAREDEKLARATION

Tillverkare: ARITERM OY  
Adress: P.O.BOX 59, FIN-43101 SAARJÄRVI  
Apparat: Biomatic+ 30 pelletsvärmecentral

- Tillverkare försäkrar,
- att vid tillverkningen av denna panna har man iakttagit väsentliga säkerhetskrav av EG rådets direktiv för tryckkärl (97/23/EY). Som värderingsmetod av överensstämmelse har använts H - modul. (notified body 0424)
  - att vid tillverkningen av brännaren har man iakttagit följande direktiven:  
EMC direktivet 89/336/EEC och maskindirektivet 98/37/EC
  - följande harmoniserade standarder har tillämpas:  
EN 303-5 ( klass 3 )  
Maskindirektiv: EN 292-1, EN 292-2  
EMC: EN 61000-6-3:2001, EN 55014-1:2001+A1:2001, EN 55011B, EN 55014, EN 61000-3-2:2001, EN 61000-3-3:1995, A1:2001, EN 55014-2:1997+A1:2002, EN 61000-6-2:2001, EN 61000-4-2, -3, -4, -5, -6, -11.

Arterm Oy  
  
Karl Väliaho  
Toimitusjohtaja  
Managing director  
Verkställande direktör

## ■ INSTALLATION REPORT

After installation, the burner must be adjusted using a flue gas analyser.

Flue gas temperature - Max	CO	O <sub>2</sub>	CO <sub>2</sub>
Combustion efficiency	Draught mm	Blower %	Auger %
Flue gas temperature - Mean	CO	O <sub>2</sub>	CO <sub>2</sub>
Combustion efficiency	Draught mm	Blower %	Auger %
Flue gas temperature - Min	CO	O <sub>2</sub>	CO <sub>2</sub>
Combustion efficiency	Draught mm	Blower %	Auger %

Dealer / Installer

Installer

Date













ARITERM SWEDEN AB | Flottljvägen 15  
39241 Kalmár | [www.ariterm.se](http://www.ariterm.se) | 0771-442850

