

ARITERM PELLET SYSTEM

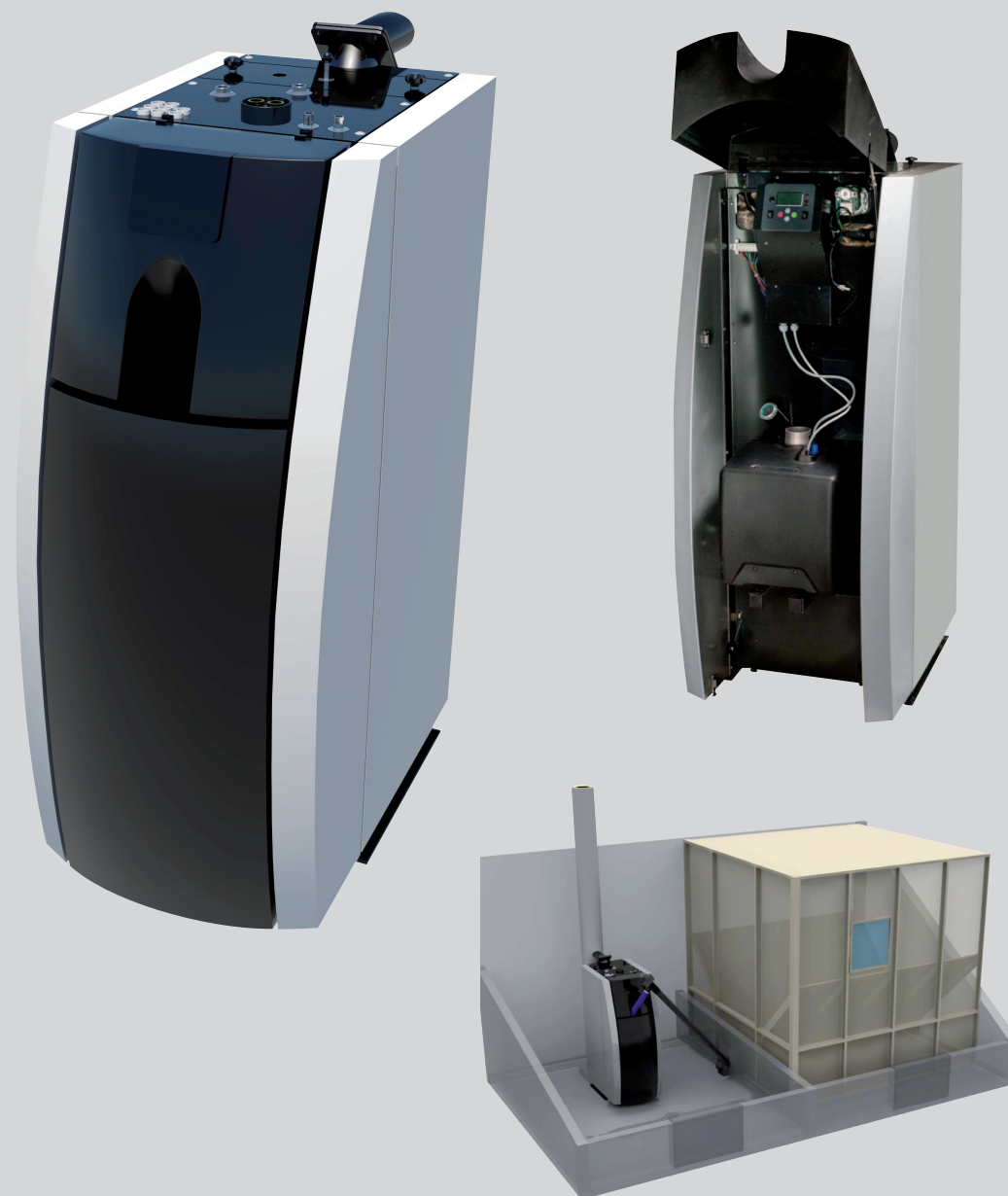

■ Arterm Biomatic+ 20 – Next generation of integrated pellet boilers

Arterm Biomatic+ 20 is an economical, reliable and environmentally friendly combination of central heating boiler and pellet burner, which is intended for heating houses and for the production of hot water.

The boiler has a new modern design which is combined with our renowned safe and reliable pellet boiler in a new model with an aluminium body. The best possible comfort, environmental performance and efficiency (91%) to meet the requirements for easy handling and effective pellet lighting.

Biomatic+ 20 has a vertical convection system with motor driven automatic sweeping of the convection tubes that reduce the deposits, which means that the boiler can maintain a high degree of efficiency between service intervals. The need for a service depends on the quality of the pellet and achieved output (fuel consumption) and varies throughout the year.

The generously sized ash container is simple to pull out and empty. The container has a volume of 50 litres which corresponds to the volume of ash normally obtained at a combustion of 2 tons of pellets at 0.5 % ash content and normal volume weight.

Automatic control

The control system is specially designed for pellet combustion and permits efficient control at 3 different settings. The control display provides information about operational status, such as, boiler temperature, exhaust temperature, rate of pellet consumption, amount of pellets remaining in storage, warning functions, etc.

From the point of view of convenience, Biomatic+ 20 shows its true advantages when it forms part of a complete pellet system with feeding from a storage container which is filled by the pellets being blown in from the bulk vehicle.

Light and Ultra Light

Biomatic+ 20 is available in a basic version without immersion heater - Biomatic+ 20 Light, and without immersion heater, hot water exchanger and charging pump - Biomatic+ 20 Ultra Light.

ARITERM SWEDEN AB

Flottiljvägen 15, SE-392 41 Kalmar

www.ariterm.se

PELLET BOILER BIOMATIC+ 20

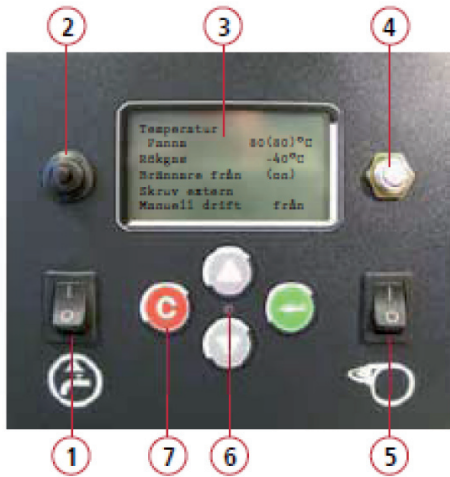

Control unit

1. Switch for inner circulation pump
2. Fuse for inner circulation pump
3. Display
4. Overheat protection
5. Main switch
6. Indication of operation and alarm with signal lamp
7. Keypad

Biomatic+ 20		
Output, pellets	kW	8-20
Output, electricity	kW	6-9
Water volume, boiler	liter	140
Weight (gross)	kg	245
Rec. draught ratio	mm vp	0,5-2,0
Rec. chimney diameter	Ø mm	100

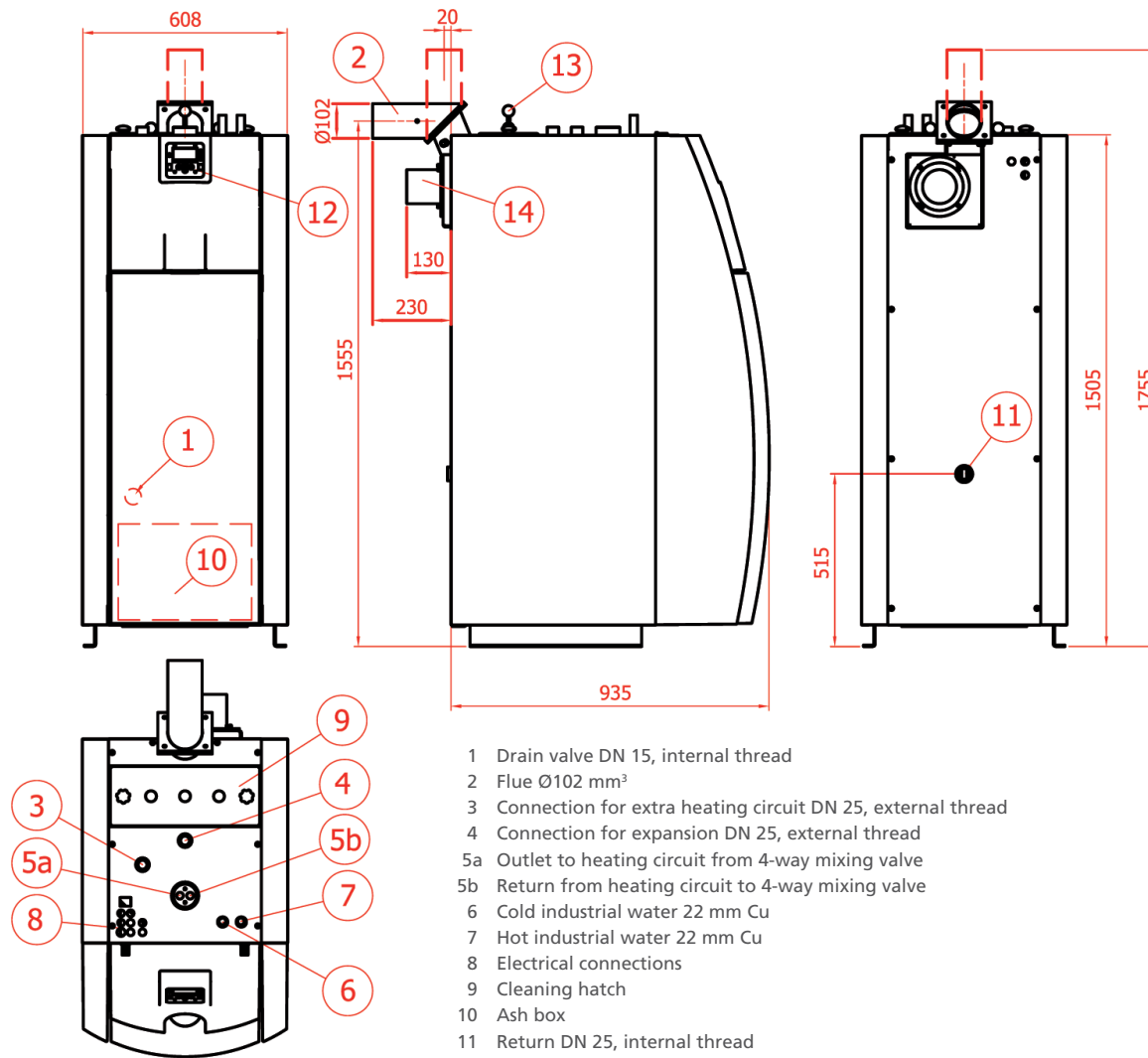

- 1 Drain valve DN 15, internal thread
- 2 Flue Ø102 mm³
- 3 Connection for extra heating circuit DN 25, external thread
- 4 Connection for expansion DN 25, external thread
- 5a Outlet to heating circuit from 4-way mixing valve
- 5b Return from heating circuit to 4-way mixing valve
- 6 Cold industrial water 22 mm Cu
- 7 Hot industrial water 22 mm Cu
- 8 Electrical connections
- 9 Cleaning hatch
- 10 Ash box
- 11 Return DN 25, internal thread
- 12 Display/keypad
- 13 Sweeping device for convection part
- 14 Flue gas fan

Included in the delivery:

- 4-way mixing valve ESBE TM 20
- Sweeping tool
- Silt filter
- Masonry support
- Flue's joint piece
- Shunt motor ESBE ARA661 3-point SPDT 230Vac 6Nm 120s
- Outdoor temperature sensor
- Room temperature sensor
- Flow line water's temperature sensor
- Flue gas fan
- Convection part's cleaning automatic device
- Flow sensor

Accessories:

- Combined flue
- Oxygen reading (the fan's output control)
- Shunt motor 2 ARA661 3-point SPDT 230Vac 6Nm 120s
- Temperature sensor 2 for flow line water