

ARITERM

INSTALLATION AND OPERATION MANUAL

Arimax Bio 120-3000 kW



TABLE OF CONTENTS

General information	2
Installation	4-9
Commissioning	10
Service and maintenance.....	11-14
Accessories, guarantee and decommissioning.....	15
Boiler connections	16-17
Declaration of conformity.....	18-19
Notes	20

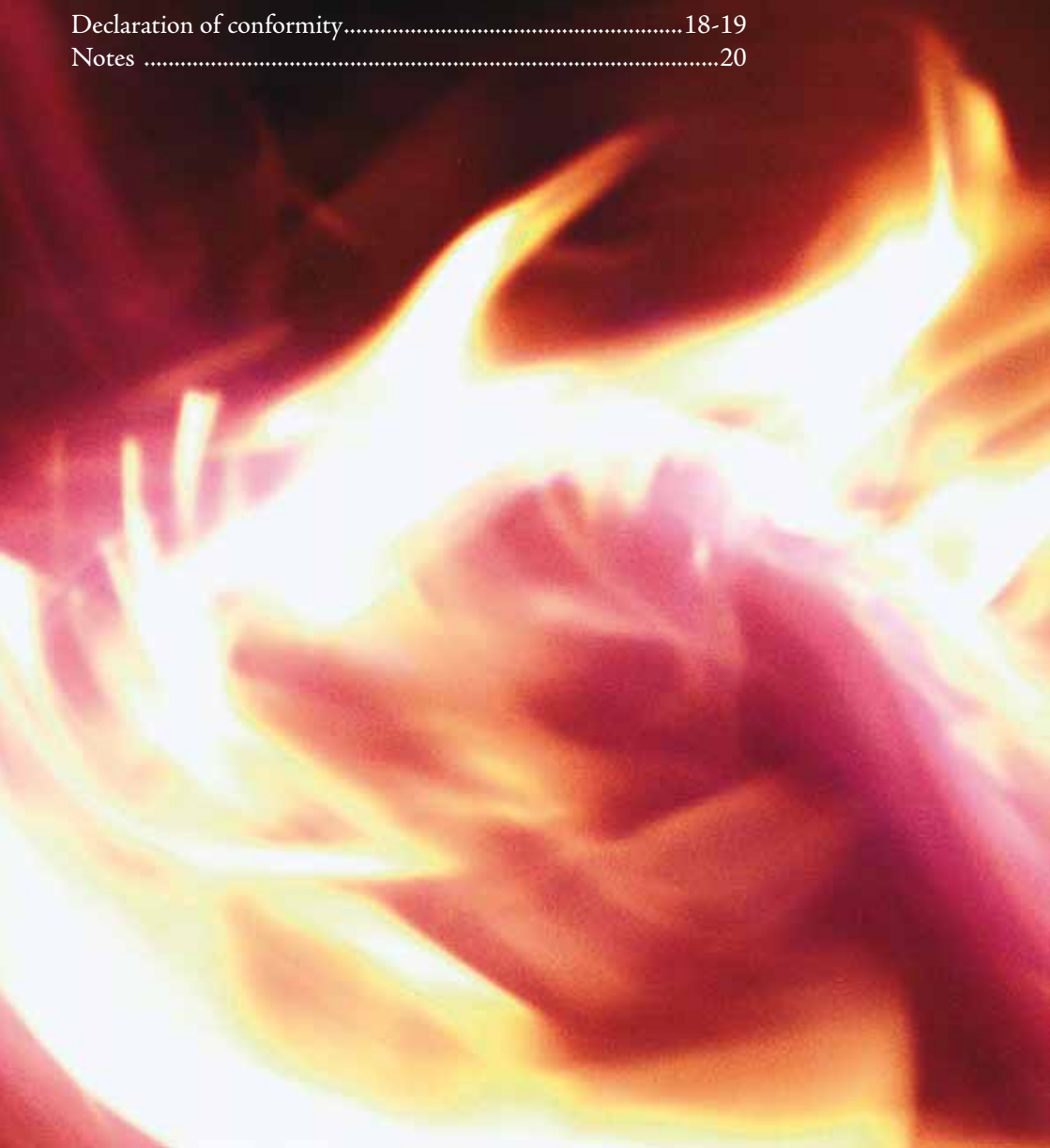

■ General information

Arimax Bio 120-3000 is a cost-effective, resistant and environmentally friendly central heating boiler for different biofuels. The boiler can be used with different fuels. In order to exploit all the features of the boiler, it is important to follow these instructions.

■ Transport, storage and package opening

Receipt and acceptance

The boiler can be safely lifted from the hoist brackets. The transport weight is stamped on the machine plate of the boiler. If the boiler is handled by means of a forklift or another similar machine, it should be noted that the bottom is open in the furnace area. The bottom of the boilers equipped with a factory-made ash pan is closed. The package should be unwrapped as close to the installation site as possible. The factory has insured the boiler against damage during transport from the factory to the first intermediate storage site. It is important for the person who receives the boiler to verify the state of the boiler before its acceptance. In cases of damage, the dealer must be contacted without delay. In addition, the content of the delivery must be checked and all possible deficiencies must be immediately notified to our factory.

Storage

The boiler can be stored outside under a rain cover. However, the preferred option is to store it inside.

Package opening

After opening the package, open the hatch and check the final inspection report to make sure that all loose accessories are contained in the package. Disposing of the package: the plastic cover is landfill waste and the boards can be burned. Beware of the insulating plates during transport. The hatches and other loose parts should be unfastened during installation.

UK Smoke Control Instructions

These instructions are intended for use when using any of the below appliances in a Smoke Control Area, when fitted with the correct burner.

- Arimax 300: Fitted with Biojet Burner 300
- Arimax 400: Fitted with Biojet Burner 400
- Arimax 500: Fitted with Biojet Burner 500

Fuel, the fuel type that the appliances have been tested on and exempted are wood pellets meeting the below criteria:

- Diameter 6 – 8 mm
- Length 5 – 40 mm
- Moisture < 10 %
- Ash content < 0,5 %
- Net caloric value 4,6 – 4,9 kWh/kg

■ INSTALLATION

The installation must be carried out in compliance with the standards in force. Since the boiler is delivered without accessories such as safety valves and other similar parts, the company responsible for the installation of the boiler must request that the specified plant (e.g. Inspecta Oy) carry out the inspection of the whole device before its commissioning.

The bio boiler series is only intended for use with combustion devices equipped with a burner head. The boiler must not be manually filled in such a way that, for example, fuel is loaded onto the furnace bed.

The boiler has been built in such a way that its lower part is open in correspondence of both the furnace and convection part. Due to this, an installation base must be manufactured for the boiler in accordance with the figure. This installation base serves as ash pan. Ash removal hatches or devices for the mechanical removal of ash can be installed on it. The joint between the boiler and installation base must be sealed extremely carefully by means of a fire-resistant mass. The aim is to prevent gas from leaking between the different ducts of the boiler.

A boiler equipped with a factory-delivered ash pan does not need a separate installation base. NB! The boilers do not contain blast hatches. In the model to be cleaned from the top, a clearance about as high as the boiler must be left on top of the boiler for the cleaning of the convection part. In the model to be cleaned from the side, a space about as wide as the boiler is needed next to the cleanout hatches. It is advisable to equip the 500-700 kW boilers to be cleaned from the side with two-sided convection cleanout hatches (optional). In the models to be automatically cleaned, the above-mentioned dimensions can be slightly smaller. In any case, it must be possible to open the convection hatches in order to carry out possible actions.

In the boiler room there must be a big enough fresh air ventilator so that the air speed in it does not exceed the value of 1.5 m/s.

ASH PAN DIMENSIONING

The ash pan can be created on site in accordance with the dimension drawing by casting concrete or by means of tiles. Alternatively, the boiler can be delivered with a steel stand. The dimension h is the minimum height of the ash pan.

The factory-made ash pan is manufactured from steel and is welded to the boiler frame. The ash pan is insulated by means of wool and an insulating plate. The ash pan is internally lined with ceramic tiles near the furnace.

Power	a	b	c	h
120	825	730	540	300
150	925	730	540	300

Power range 120 - 150 kW

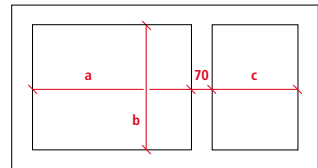
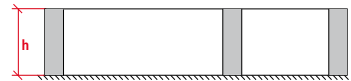

Power	a	b	c	d	h
200	925	730	536	135	300
250	1025	780	536	135	300
300	1125	830	596	155	300
400	1225	930	596	155	300

Power range 200 - 400 kW

Chimney pipe in the mounting tray

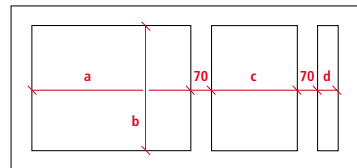
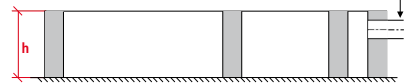

Power	a	b	c	d	e	h
500	1325	1030	354	334	135	500
700	1625	1230	354	334	135	800
1000	1725	1430	596	374	155	800
1500	2025	1630	596	374	155	800
2000	2325	1730	1040	374	155	1000
2500	2925	1730	1040	374	155	1000
3000	3525	1730	1040	374	155	1000

Power range 500 - 3000 kW

Chimney pipe in the mounting tray

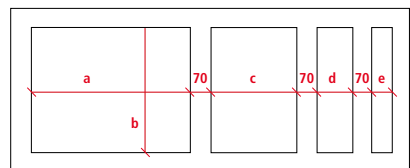

■ INSTALLATION

■ Arimax Bio 120-3000 kW stack recommendations

In five-draught boilers with a power of over 500 kW, the diameter of the stack is defined according to the flue gas blower to be used (pressure increase / flow rate - pressure loss)

Minimum diameter of the stack pipes (flow rate 16 m/s)

Boiler power kW	500	700	1000	1500	2000	2500	3000
Stack Ø mm	200	250	300	350	400	450	500

The height of the stacks is chosen on the basis of the building requirements and other environmental requirements.

■ Natural-draught boilers of less than 400 kW

Stack recommendations

Boiler power kW	120	150	200	250	300	400
Stack Ø mm (or square side) mm	200	230	250	300	330	350
Stack length m	9	10	12	14	15	15

The values of the table have been calculated using wood chips of good quality (moisture 35 %) and a well-controlled burning process (residual oxygen max 8 %). When using wetter or otherwise different fuel, the stack must be dimensioned on a case-by-case basis.

If necessary, also natural-draught boilers can be equipped with a flue gas blower. Ask the factory for the dimensions!

■ INSTALLATION

■ Pipe installations

The connection of the boiler to the pipe system must be designed and realised in a professional way and in compliance with the regulations in force. The components to be used must be selected taking into account the high pressure and working temperature of the plant. CE marked components that meet the fundamental safety requirements of the Pressure Device Directive must be used as pressure bearing components.

The most important values from the point of view of the installation and safe use are in the boiler plate.

The boiler must be equipped with at least the following accessories:

- Thermometers for the measurement of the temperature in the supply and return pipes of the boiler
- Manometer for the measurement of the pressure in the boiler.
- Boiler thermostat or sensor for the control of the fuel input power.
- Overheat protection that stops the fuel feeding process in overheat situations.
- Safety devices that work when the maximum allowable pressure is exceeded = safety valve(s) whose opening pressure is at most equal to the working pressure of the boiler and whose blowdown efficiency is sufficient to prevent the boiler pressure from increasing by over 10 % of the working pressure in case of boiling. Devices by means of which the connection can be closed must not be installed between the safety valve and the boiler or the water-running burner head.
- The safety device to be connected to the boiler must be a class IV pressure device.
- Dry-boiling protection that stops the fuel feeding process when the boiler water surface goes down (in boilers with a power of over 120 kW).
- Expansion tank for liquid volume changes
- Flange for fastening the inspection manometer.
- Discharge valve in the lowest part of the boiler.
- Filling group to increase the amount of boiler water

NB! In order to ensure the durability and good operation of the boiler, the return water temperature should never be less than 65 degrees! The mixing pump (P2) that can be seen in the connection diagram ensures this. Cold return water increases susceptibility to corrosion and impairs combustion!

INSTALLATION

Blowdown efficiencies required for the safety valves

Working pressure	4 bar	6 bar	10 bar
Boiler power kW	Blowdown efficiency kg/h (steam)		
40	62,5		
60	97,8		
80	130,4		
100	163		
120	195,6	195,6	
150	244,5	244,5	
200	326	326	
250	407,7	407,5	
300	489	489	
400	665,2	665,2	
500	815	815	815
700	1141	1141	1141
1000	1630	1630	1630
1500	2445	2445	2445
2000	3260	3260	3260
2500	4075	4075	4075
3000	4890	4890	4890

Two safety valves must be installed and their blowdown efficiency must be at least according to the adjacent table.

The safety valves must be chosen in accordance with the heating, plumbing and air conditioning plan of the plant in question.

The blowdown pipe of the safety valve must be dimensioned and installed in such a way that it does not limit the valve blowdown efficiency and does not cause dangerous situations during the operation of the valve.

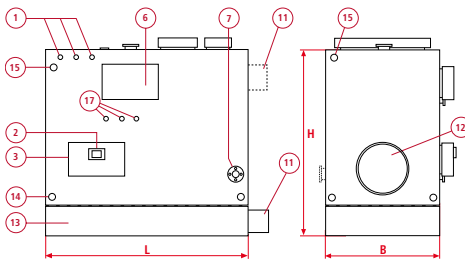

Model to be cleaned from the top

1. Thermostat units
2. Flame inspection glass
3. Burner head / furnace service hatch
4. Expansion valve / safety valve unit
5. Output unit
6. Oil burner flange (optional)
7. Return unit
8. Front convector cleaning
9. Back convector cleaning
10. Flue damper
11. Flue duct
12. Oil burner hatch (optional)
13. Burner opening (may also be on the side of the boiler)
14. Ash pan (optional)
15. Inspection units of the boiler water space (in the lower corners)
16. Cooling circuit unit of the burner head

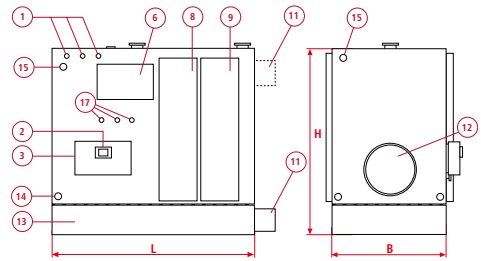

Model to be cleaned from the side

Models to be cleaned from the side:

- 120 - 700 kW, cleaning from the side chosen by the client
 - Accessory: 120 - 700 kW, cleaning from both sides
 - Recommendation: 500 - 700 kW boilers, cleaning from both sides
17. Automatic sweeping units
 18. Furnace measurement units
 19. Flue gas heat unit / analysis unit
 20. Lambda sensor unit
 21. Flue gas measurement units (2 pcs)

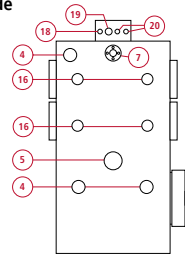
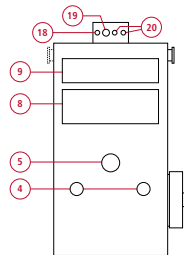

INSTALLATION

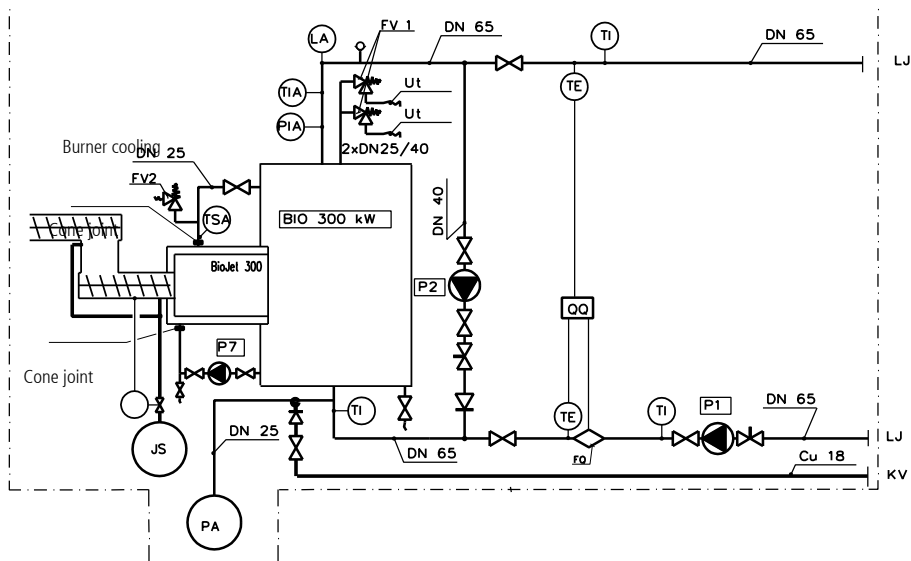

Code	Device	Hank
DOMESTIC WATER EQUIPMENT, ACCESSORY, VERSION 1		
P 3	HOT WATER CIRCULATION PUMP, GRUNDFOS UP 20-15 N	LK
P 5	HOT WATER SUPPLY PUMP, GRUNDFOS UPS 25-40	LK
KV 2	DOMESTIC WATER HEAT EXCHANGER SWEP E 30 N	LK
SV 2	3-WAY VALVE, kv1, 6 HONEYWELL V5823A 2045	LKPU
FV 3	SAFETY VALVE, DN 15 / 1.0 MPA	LKPU

Indicative connection diagram. The boiler is equipped with a water-cooled Biojet burner.

Code	Device
DOMESTIC WATER EQUIPMENT, ACCESSORY, VERSION 2	
P 4	DOMESTIC HOT WATER PUMP, GRUNDFOS UP 20-45 N
P 6	HOT WATER SUPPLY PUMP, GRUNDFOS UPS 32-80
KV 3	DOMESTIC WATER HEAT EXCHANGER LPM HL 1-32
SV 3	3-WAY VALVE, kv2, 5 HONEYWELL V5823A 2052
FV 4	SAFETY VALVE, DN 20 / 1.0 MPA
P 1	HOT WATER SUPPLY PUMP, GRUNDFOS UPE 50-120 F
P 2	HOT WATER SUPPLY PUMP, GRUNDFOS UPS 25-80
P 7	HOT WATER SUPPLY PUMP, GRUNDFOS UPS 25-60
SV 1	3-WAY VALVE, 3.0 L/S 10KPA (kv 35)
FV 1	SAFETY VALVE, DN 25/40/400 KPA 510 KG/H
FV 2	SAFETY VALVE, DN 15/400 KPA
PA	EXPANSION VESSEL 300 L, PRE-CHARGE 100 KPA
LA	DRY-BOILING PROTECTION, LABKO SET61+SET/11
TIA	ALARM THERMOMETER 0...+130 °C
TI	THERMOMETER, 0...+130 °C
PIA	ALARM MANOMETER, 0... 600 KPA
AVTA	SELF-OPERATED CONTROL VALVE DN 25
TSA	OVERHEAT PROTECTION 90...+120 °C, TRAFAG MST15015
QQ/FQ	ENERGY METER, KAMSTRUP MC/UF 15 DN 50/270
	SHUT-OFF VALVE
	THROTTLING VALVE
	CHECK VALVE
	AUTOMATIC DEAERATOR

COMMISSIONING

Before starting the boiler, it must be ensured that the boiler is filled with water and that the valves and flue dampers are open. If the furnace is lined with ceramic tiles, preheating must be carried out with extreme caution. From the point of view of the durability of the heating surfaces, it is useful to use the driest possible fuel. If wood chips with higher water content (over 30 %) are used, tiles must be installed in the furnace in order to obtain a good combustion result. If the boiler must be kept standing, for example, during summer, it must be immediately cleaned and the flue damper must be kept closed in order to prevent corrosion.

Influence of fuel moisture on flue gas temperature at different loads.

- The efficiency decreases with increasing fuel moisture. Fuel consumption increases.
- The efficiency increases with decreasing fuel moisture. Fuel consumption is low.

Daily use

The Arimax Bio 120 - 3000 boilers are intended for use with automatic feeding devices. Instructions on the control and alarm functions related to fuel feeding and burning have been included in the operating instructions of the devices in question. From the point of view of the safe use of the boiler, it is important to follow all instructions of the devices to be connected to this boiler.

From the point of view of the boiler, it is important to follow the following things:

- Tightness of the hatches.
- Boiler water temperature and pressure.
- Ash accumulation; the ash surface must not touch the burner head.
- Changes in the flue gas heat; an increase in the flue gas temperature means that cleaning is needed.

Note! While using crops as fuel, have to make sure by pipe connections and valves, that the inlet water temperature is over 80°C to prevent formation of corrosive condensation on heating surfaces. It is also important to regularly control the heating surfaces of the boiler.

It is good to comprehend that every fuel has its own impact on boiler's operating life.

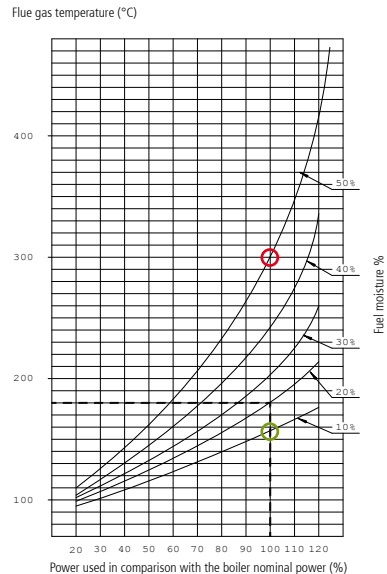

○ Increased humidity results in decreased efficiency. Fuel consumption will increase.

○ Dry fuel means higher efficiency. Fuel consumption will be optimal

■ SERVICE AND MAINTENANCE

In order to ensure the cost-effective and safe operation of the boiler, preventive maintenance should be carried out on the boiler and the devices connected to it and the emissions should be regularly measured.

- Operation of safety and alarm devices:
- Opening of safety valves
- Overheat protection testing
- Expansion system inspection
- Dry-boiling protection testing
- Testing of the operation of alarm thermometers and manometers
- Extinguishing equipment testing
- Keep the boiler and its environment dust free. Make sure that there are no flammable objects or materials near the ash pan.
- Check the tightness of the hatches and adjust it as needed. Blast hatches: Tighten the hatches only as needed in order to obtain the required tightness. Leave enough "blast space" for the springs of the hatches.
- Cleaning of the heating surfaces, especially the convector, as needed.
- Service and cleaning of ducts and possible flue gas removal devices.

■ Cleaning

The furnace is cleaned through the fire hatch of the boiler. The boilers equipped with a furnace shelf also have a service hatch in the upper part of the furnace. The burner or firing equipment is serviced through the fire hatch. The cleanliness of the convectors significantly affects the efficiency of the boiler. In the model to be cleaned from the top, the convection part is cleaned from the hatches located on the top of the boiler by vertically brushing all gaps. In the model to be cleaned from the side, the convection part is best cleaned by means of a rotating brush used with a drilling machine.

The detached soot flows to the ash pan located under the convector and from there it is removed after cleaning.

■ SERVICE AND MAINTENANCE

■ How to sweep the Arimax Bio boiler 120-300 kW (model to be cleaned from the top)

NB! The boiler is easier to clean if it is first let to cool down for a moment. The burner must not be on during cleaning! The flue gas exhauster should be kept on during sweeping. This reduces the amount of ash that accumulates in the boiler room.



1. Open the sweeping hatches located on the top of the boiler.



2. Fasten the brush part to the handle and brush one duct at a time.



3. Push the brush down and then pull it up.



4. Sweep the ash fallen onto the ash pan and put it in the ash box.

■ SERVICE AND MAINTENANCE

The following accessories are included:



1. Sweeping brush handle
2. Ash rake
3. Sweeping brush handle, rotating (models to be cleaned from the side)
4. Sweeping brush
5. Sweeping brush, rotating (models to be cleaned from the side)
6. Hatch handles and hinge tool
7. Ash shelf (under the hatch)
8. Extension device of the sweeping arm
9. Ash box
10. Combined thermometer/manometer and flue gas thermometer.

■ SERVICE AND MAINTENANCE

■ How to sweep the Arimax Bio boiler 120-700 kW (model to be cleaned from the side)



1. Open the sweeping hatches located on the side of the boiler.



2. Fasten the rotating brush to the handle and then these to the drilling machine.



3. Push the brush to the convection part



4. Correct grip: one hand on the drilling machine and the other on the sweeping arm.

Evenly clean the convection part using a rotating brush (a few gaps at a time). Keep the handle horizontal the whole time. Repeat the same procedure until the convection part is completely cleaned.



5. Sweep the ash fallen onto the ash pan and put it in the ash box.



6. The furnace does not usually require separate cleaning. Correctly regulated combustion keeps the furnace clean. An ash shelf is installed under the furnace hatch.

■ ACCESSORIES, GUARANTEE AND DECOMMISSIONING

Different accessories that make operation and service easier are available for the Arimax Bio central heating boilers.

- Additional hatches of the furnace.
- Oil burner hatch; Hinged hatch in which there are a blind flange and a hole for the oil burner. Reserve power to be quickly taken into use.
- Oil burner hatch; Furnace hatch with oil burner hole
- Hatch on both sides of the convector (models to be cleaned from the side)
- Insulated steel ash stand
- Ash-removal screws to be installed on the ash stand
- Ash aspirator (separate unit). Thanks to the ash aspirator, also the boiler room remains clean.
- Flue gas exhauster
- Flue gas cleaner
- Automatic sweeping with compressed air. It keeps the convector clean and service-free and continuously guarantees the efficiency of a clean boiler!

Ask the factory for additional information about this!

■ Guarantee

Arterm Oy gives a two-year guarantee on the boiler starting from the date of installation. The guarantee covers the faults related to work and raw materials that may appear in the boiler.

The manufacturer assumes no guarantee liability if the defect has been caused by an installation fault, leaks outside the boiler, faulty operation, freezing, overheat or overpressure. If the repair operations have been started without the manufacturer's permission or the guarantee card has not been returned to the factory, the guarantee is not valid. The factory is not responsible for the possible consequential damages and costs caused by the boiler.

The guarantee does not cover corrosion of the boiler caused by faulty operation.

Arterm Oy reserves the right to decide the way in which the guarantee repair is carried out. Arterm Oy is not liable for the damages that remain outside the guarantee period. If the boiler is structurally changed, the declaration of conformity given by Arterm Oy is not valid.

■ Decommissioning

An end-of-life boiler is suitable for scrapping.

BOILER CONNECTIONS, model to cleaned from the side

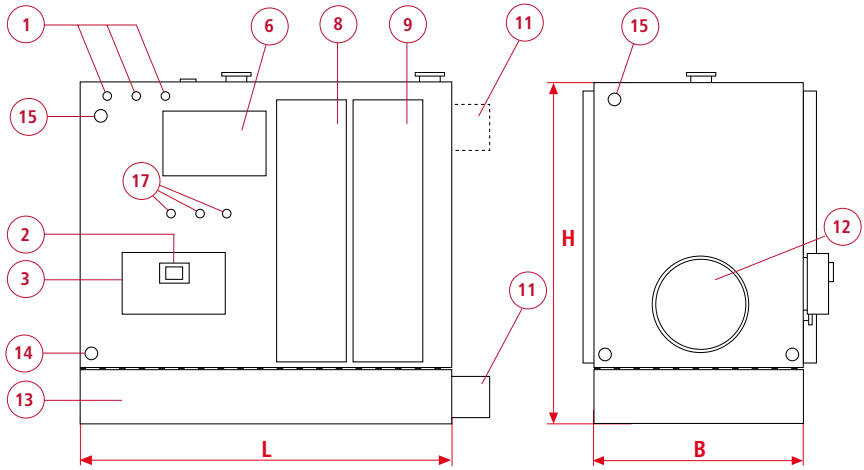

1. Thermostat units
2. Flame inspection glass
3. Burner head / furnace service hatch
4. Expansion valve / safety valve unit
5. Output unit
6. Oil burner flange (optional)
7. Return unit
8. Front convector cleaning
9. Back convector cleaning
10. Flue damper
11. Flue duct
12. Burner opening
(may also be on the side of the boiler)
13. Ash pan (optional)
14. Inspection units of the boiler water space
(in the lower corners)
15. Cooling circuit unit of the burner head
 - 120 - 700 kW, cleaning from the side chosen by the client
 - Accessory: 120 - 700 kW, cleaning from both sides
 - Recommendation: 500 - 700 kW boilers, cleaning from both sides
16. Automatic sweeping units
17. Furnace measurement units
18. Flue gas heat unit / analysis unit
19. Lambda sensor unit
20. Flue gas measurement units (2 pcs)

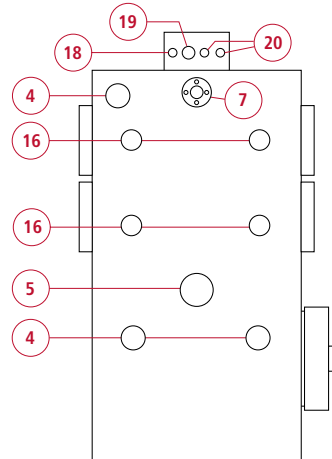

■ BOILER CONNECTIONS, model to cleaned from the top

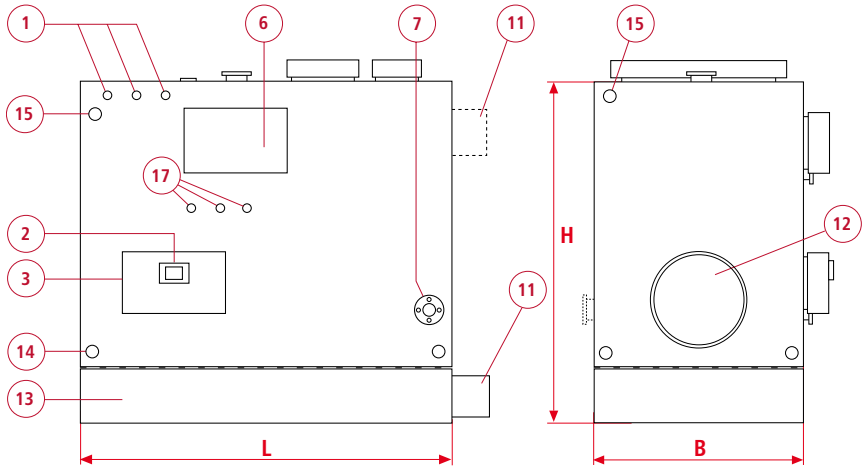

1. Thermostat units
2. Flame inspection glass
3. Burner head / furnace service hatch
4. Expansion valve / safety valve unit
5. Output unit
6. Oil burner flange (optional)
7. Return unit
8. Front convector cleaning
9. Back convector cleaning
10. Flue damper
11. Flue duct
12. Burner opening
(may also be on the side of the boiler)
13. Ash pan (optional)
14. Inspection units of the boiler water space
(in the lower corners)
15. Cooling circuit unit of the burner head
16. Automatic sweeping units
17. Furnace measurement units

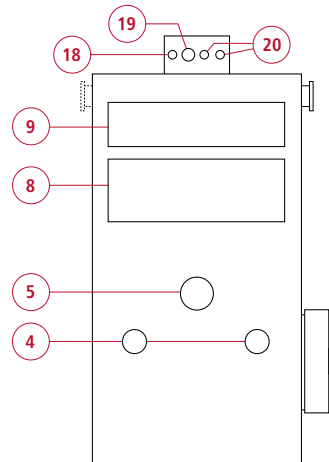

DECLARATION OF CONFORMITY



VAATIMUSTENMUKAISUUSVAKUUTUS

Valmistaja: ARITERM OY
Osoite: PL 59, 43101 SAARIJÄRVI

Laite: **Arimax keskuslämmityskattila**

Valmistaja vakuuttaa,

- että tämän yksilön valmistuksessa on huomioitu Euroopan yhteisön neuvoston painelaitedirektiivin (97/23/EY) olennaiset turvallisuusvaatimukset.
- että vaatimustenmukaisuuden arviointimenettelyinä on käytetty H - moduulia. (ilmoitettu laitos 0424)
- että riskinarviointimenettely on suoritettu konedirektiivin 2006/42/EY mukaisesti (standardi SFS-EN ISO 14121-1)
- Toimitukseen ei sisälly varolaitteet.

DECLARATION OF CONFORMITY - MANUFACTURERS DECLARATION

Manufacturer: ARITERM OY
Address: P.O.BOX 59, FIN-43101 SAARIJÄRVI

Equipment: **Arimax central heating boiler**

Manufacturer assures,

- that in production of above mentioned example has been observed the essential safety demands of EC council's directive for pressure vessels (97/23/EY).
- as estimation method of conformity has been used H - module. (notified body 0424)
- that estimation method of risks has been carried out according to the machinery directive 2006/42/EY (standard SFS-EN ISO 14121-1)
- Safety device are not included in the delivery.

FÖRSÄKRAN OM ÖVERENSSTÄMMELSE - TILLVERKAREDEKLARATION

Tillverkare: ARITERM OY
Adress: P.O.BOX 59, FIN-43101 SAARIJÄRVI

Apparat: **Arimax centralvärmepanna**

Tillverkare försäkrar,

- att vid tillverkningen av ovannämnda exempel har man iakttagit väsentliga säkerhetskrav av EG rådets direktiv för tryckkärl (97/23/EY).
- som värderingsmetod av överensstämmelse har använts H - modul. (notified body 0424)
- att riskanalysmetod on utförd i enlighet med maskindirektiven 2006/42/EY (standard SFS-EN ISO 14121-1).
- Säkerhetsutrustning ingår inte i leveransen.

30.3.2010 Ariterm Oy

Petteri Korpioja
Toimitusjohtaja
Managing director
Verkställande direktör

DECLARATION OF CONFORMITY



VAATIMUSTENMUKAISUUSVAKUUTUS

Valmistaja: ARITERM OY
Osoite: PL 59, 43101 SAARIJÄRVI

Laite: **Arimax Bio 200 – 3000 4-10 bar keskuslämmityskattila**

Valmistaja vakuuttaa,

- että tämän yksilön valmistuksessa on huomioitu Euroopan yhteisön neuvoston painelaitedirektiivin (97/23/EY) olennaiset turvallisuusvaatimukset.
- että vaatimustenmukaisuuden arviointimenettelynä on käytetty H - moduulia. (ilmoitettu laitos 0424)
- että riskinarviointimenettely on suoritettu konedirektiivin 2006/42/EY mukaisesti (standardi SFS-EN ISO 14121-1)
- Toimitukseen ei sisälly varolaitteet.

DECLARATION OF COMFORMITY - MANUFACTURERS DECLARATION

Manufacturer: ARITERM OY
Address: P.O.BOX 59, FIN-43101 SAARIJÄRVI

Equipment: **Arimax Bio 200 – 3000 4-10 bar central heating boiler**

Manufacturer assures,

- that in production of above mentioned example has been observed the essential safety demands of EC council's directive for pressure vessels (97/23/EC).
- as estimation method of conformity has been used H - module. (notified body 0424)
- that estimation method of risks has been carried out according to the machinery directive 2006/42/EC (standard SFS-EN ISO 14121-1)
- Safety device are not included in the delivery.

FÖRSÄKRAN OM ÖVERENSSTÄMMELSE - TILLVERKAREDEKLARATION

Tillverkare: ARITERM OY
Address: P.O.BOX 59, FIN-43101 SAARIJÄRVI

Apparat: **Arimax Bio 200 – 3000 4-10 bar centralvärmepanna**

Tillverkare försäkrar,

- att vid tillverkningen av ovannämnda exempel har man iakttagit väsentliga säkerhetskrav av EG rådets direktiv för tryckkärl (97/23/EG).
- som värderingsmetod av överensstämmelse har använts H - modul. (notified body 0424)
- att riskanalytmetod on utförd i enlighet med maskindirektiven 2006/42/EG (standard SFS-EN ISO 14121-1).
- Säkerhetsutrustning ingår inte i leveransen.

20.1.2011, Ariterm Oy

Petteri Korpioja
Toimitusjohtaja
Managing director
Verkställande direktör



ARITERM

ARITERM OY | PL 59, 43101 Saarijärvi, Finland
Tel. +358 14 426 300, fax +358 14 422 203 | www.ariterm.fi

ORGANISATION
CERTIFIED BY
Inspecta

ISO 9001
ISO 14001