

ARITERM WOOD FIRED BOILERS

ARITERM

For a sustainable future



Ariterm Vedo contains a suction fan that gives even combustion and minimal risk of smoking when filling with wood.



It is easy to access the grate, ashbox and wood filler hatch through the front hatch. The convection surfaces are cleaned simply via a separate hatch on the upper side.

■ Modern design and high efficiency

Ariterm Vedo is an efficient and modern wood fired boiler for connection to an accumulator tank and can also be equipped with a pellet burner. Vedo fulfils the latest and highest standards (class 3) of the European norms for minimal emissions and best efficiency levels.

Thanks to the boiler's optimum combustion, high efficiency convection surfaces and excellent insulation a high boiler efficiency (90%) and limited environmental emissions are achieved.

■ Easily positioned and centrally controlled

Despite the compact format Vedo has a large hearth of 120 litres. The format simplifies positioning because management is handled via a separate control unit with a digital display.

■ Spacious ceramic hearth

Ariterm Vedo is fired with half meter logs, which are placed on the ceramic grate in the hearth that is surrounded by a water jacket. Vedo works according to the principle of "bottom combustion" where the wood is gasified and combusts efficiently under high temperature in the lower, ceramic lined part of the boiler.

■ Accumulator tank

Vedo is designed to be used with an accumulator tank. Several types of accumulator tank, suitable for most systems, are available in the Ariterm range. A suitable volume is 1500-2500 litres.

■ Pellet fired

Ariterm Vedo can be used with pellet burner KMP PX21. The burner is installed by changing the lower hatch for one equipped with KMP pellet burner adapter.

■ Solar powered system

With a complete wood and solar power system from Ariterm one has a comfortable, energy efficient and environmentally friendly heating and hot water system.

ARITERM SWEDEN AB

Flottiljvägen 15, SE - 392 41 Kalmar

www.ariterm.se

WOOD FIRED BOILER ARITERM VEDO

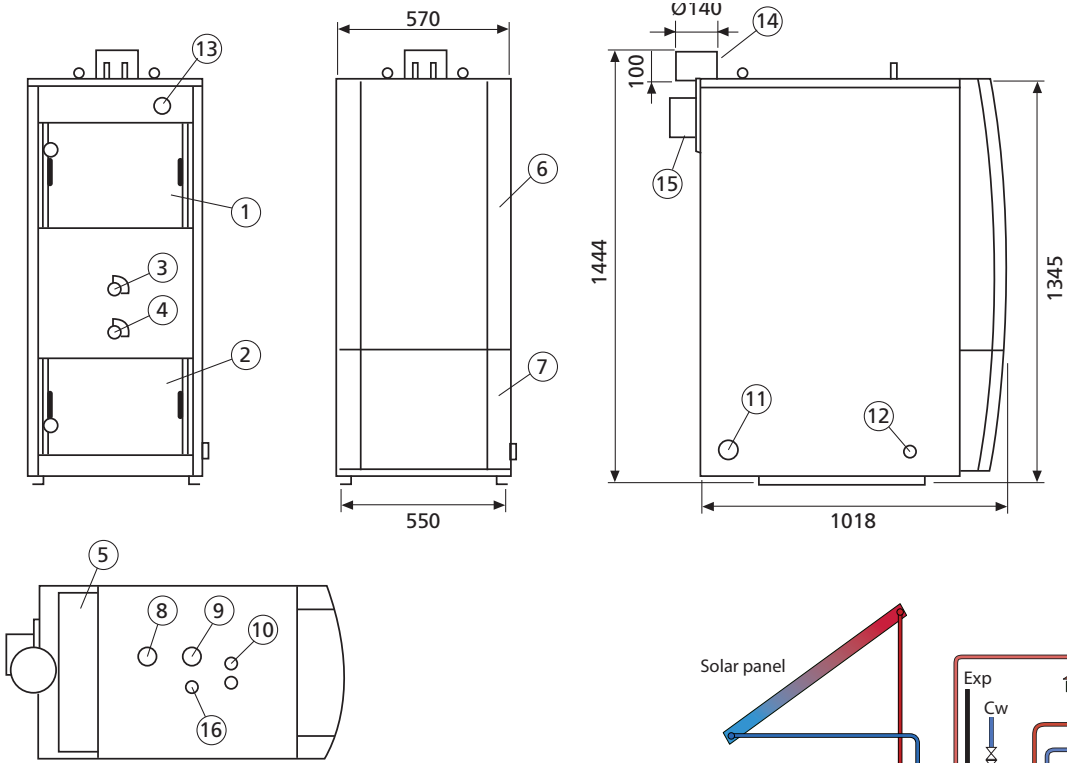

- Connections:**
- 1 Filling hatch
 - 2 Ash hatch
 - 3 Adjusting primary air
 - 4 Adjusting secondary air
 - 5 Soot hatch
 - 6 Upper door
 - 7 Lower door
 - 8 Supply accumulator tank DN 32
 - 9 Expansion DN 25
 - 10 Cooling coil Cu 15
 - 11 Return accumulator tank DN 32
 - 12 Connection drainage DN 15
 - 13 Boiler temperature / manometer
 - 14 Flue connection
 - 15 Smoke fan
 - 16 Sensor connection for thermal valve DN 15

Included in the delivery

- Angled flue pipe
- Sweeping tool

Accessories

- Pellet burner hatch adapted for KMP PX21
- Accumulator tank
- Temperature sensor for accumulator tank
- Solar and shunt control
- Charge automatic

Pellet fired

Pellet burner KMP PX21 is installed by changing the lower hatch for one equipped with KMP pellet burner adapter. When using the pellet burning the ceramic grate and afterburner chamber are removed and the adjustment for primary and secondary air is shut completely. Detailed instructions on how to install the pellet burner are supplied with the burner.

Immersion heaters

Arterm Vedo cannot be installed with an additional immersion heater. Any immersion heaters are installed in the accumulator tank.

Accumulation

With the appropriate charge automatic (accessory) good layering is achieved in the tank and prevents too low return temperature to the boiler. Thereby the time between each firing is extended which gives greater heating and hot water comfort. Recommended tank volume 1500-2500 litres.

Cooling coil

As standard, Arterm Vedo is equipped with a cooling coil that prevents the boiler overheating.

Chimney

When installing a new boiler the chimney should always be inspected to check seal, draw and condensation risk. An insert may need to be installed.

SYSTEM WITH WOOD FIRED BOILER, SOLAR PANEL, TANK MODULE AND SLAVE TANKS

Area of use: House.

Heat source: Wood and sun.

Function: The heat from the sun's rays is transferred in the solar panel via a circulating system with a heat exchanger and is stored in an accumulator tank module. The solar heat can be used for hot water production and heating.

As an auxiliary heater when the solar heat is not sufficient, the pellet boiler produces heat in the upper section of the tank module. When the tank module is fully charged a pump connection starts and charges the slave tanks. When auxiliary heat is required it is taken from the wood fired boiler or the slave tanks.

Comfort: With the combination of wood-sun you rarely need to fire the wood boiler during the bulk of the summer half of the year.

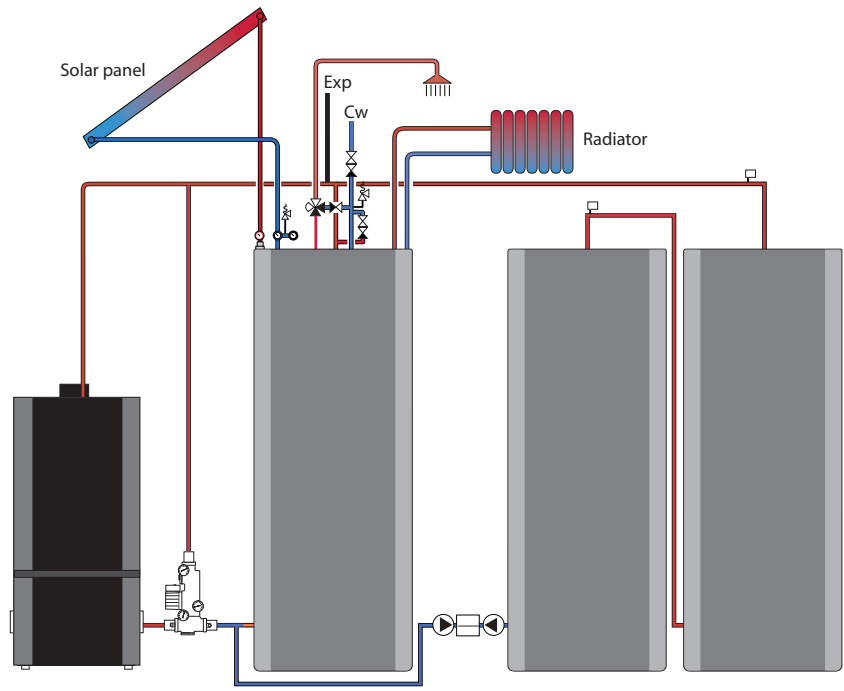

Arterm Vedo		
Output wood	kW	33
Output pellets	kW	20
Water volume boiler	litres	125
Weight (net)	kg	415
Rec. draught	mm wp	0.5-2.0
Rec. chimney diameter (outer)	Ø mm	140