

# ARITERM



## INSTALLATION, OPERATION AND MAINTENANCE

♦ Biomatic+ 50



## ■ CONTENTS

Important Information.....	2
Dimensions / Items Included / Technical Data.....	3
Operating Principle .....	4
Safety and Alarms.....	5
Installation.....	6
Water Piping .....	6-7
Filling of Water .....	8
Wiring Diagram.....	9
Start-up in OFF Mode.....	10
Start-up in Operating Mode .....	10
Settings .....	11
Burner Overview.....	11
Control Panel .....	12
Control Computer and Menus.....	12
Displayed Messages .....	13-14
Actions Chart.....	15
Troubleshooting.....	16-17
Maintenance, Care, Sweeping.....	18-20
Advice about Fuel Pellets .....	21
Guarantee .....	21
Storage Planning.....	21
Feeding System .....	22-24
Declaration of Conformity .....	25
Installation Protocol.....	26
Notes .....	27

## ■ IMPORTANT INFORMATION

- Keep this instruction manual readily available for future use.
- Read the instructions carefully before taking your pellets installation into service.
- The capacity of the burner is calculated according to the maximum volume of pellets that can be fed to and burnt in the burn pot during 1 hour (based on a normal, average wood pellets quality as described in our fuel specification)
- Follow these instructions carefully and carry out care and maintenance work as recommended.

### ■ Notification to building authority

Attention! When you change heating installation this must always be communicated to the local building authorities.

### ■ Sweeping

According to the fire protection laws a chimney shall be swept regularly. This is done by the local chimneysweep. Sweeping of the boiler shall be carried out in such a manner that good operating economy is achieved. (see under "Maintenance") Prepare to chimney-sweeping by turning off the boiler at least one hour before cleaning to minimize the amount of glowing ash.

**Warning!** Make sure to cut the power supply to the boiler before removing the burner housing.

### ■ Maintenance contract

Ariterm recommends the boiler installation to be made by a company with professional competence. For more information please contact your Ariterm retailer.

### ■ Replacing of spare parts

Ariterm recommends that replacing of spare parts is made by authorized serviceman of Ariterm retailer. The retailer supplies required spare parts and authorized serviceman makes the necessary adjustments and combustion gas analysis when replacing spare parts.

### ■ Disposal

The metal parts of the burner and the boiler can be scrapped, the plastic parts shall be disposed of in accordance with the regulations in force.

## DIMENSIONS / ITEMS INCLUDED IN THE DELIVERY / TECHNICAL DATA

### Part Number

- Biomatic+ 50 (part.no. 4013)

### Standard delivery

- Sweeping gear
- Combination flue pipe (5208)

### Accessories

- Heat exchanger unit
- Electric resistor unit

TECHNICAL DATA		
<b>Performance</b>	Output using pellets Combustion efficiency Power of ignition resistor Normal power consumption	25 - 50 kW 91 % 450 W 90 W
<b>Dimensions</b>	Dimensions (width x depth x height) Weight Water contents Weight (burner)	606 x 960 x 1730 mm 452 kg 115 l 40 kg
<b>Design values</b>	Design pressure Design temperature Recommended draught in the chimney	0,5 - 1,5 bar max 120 °C 30 Pa
<b>Connections</b>	Expansion Drain Feed line Flue pipe connection Recommended chimney diameter and length	DN 25 male DN 15 female DN 50 female Ø 139 mm Ø 150 mm, length min 6 m
<b>Electrical data</b>	Power supply Supply cable Fuse size Power in operation Power in connection	240 V 50 Hz MMJ 3x1,5s 1x10 A 90 W 600 - 720 W

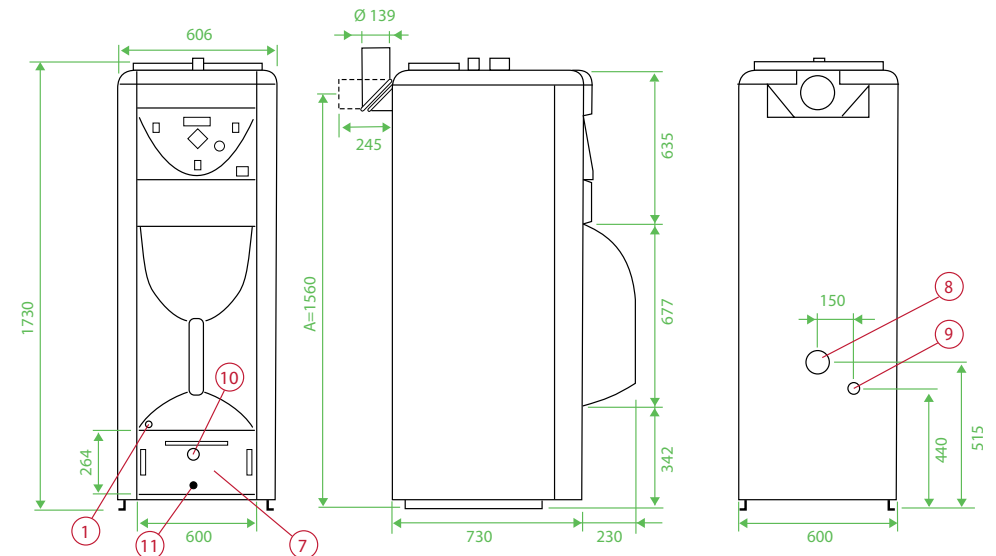

Dimensions are without adjustable feet

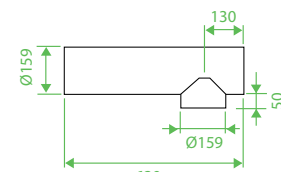
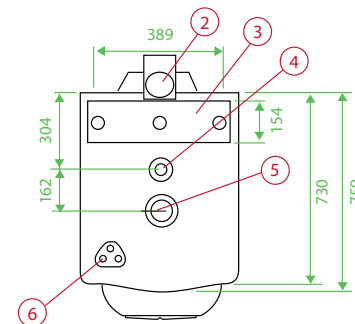

Combination flue pipe (accessory)

1. Drain DN 15, female
2. Flue pipe Ø 139 mm
3. Sweeping hatch
4. Expansion DN 25, male
5. Feed line DN 50, female
6. Cable bushing
7. Ash box
8. Return DN 50, male
9. Return DN 25, male
10. Air valve
11. Ash compression

## ■ OPERATING PRINCIPLE

Biomatic+ 50 the new generation pellet boiler is equipped with a 50 kW built-in pellet burner. A pellet burner has many similarities with an oil burner. The difference is that heating with solid fuel produces ash that must be regularly removed to prevent loss of efficiency or impairment of burner performance. The boiler is designed to meet the highest requirements as to operational reliability, convenience, and safety.

Biomatic+ 50 belongs to the most efficient state-of-the-art pellet boilers in today's marketplace. Optimal combustion efficiency and good insulation allows for a high coefficient of performance while emissions to the environment are kept at a low level. The boiler has automatic ignition but can always be ignited manually, if required. It has two ignition programs depending on whether the burner is started from the OFF position or from operating mode.

Operation of the boiler and its feed system are fully automated and are regulated in three steps by the built-in control system. In the burn pot, pellets are mixed with air to the ideal proportion to ensure complete combustion in a cost effective manner. Biomatic+ 50 is equipped with an oversized ash box to facilitate maintenance work. Sweeping is mainly done from the soot-hatch on top of the boiler but also through the rebox door after the burner is pulled out.

Biomatic+ 50 consists of a combustion chamber with flue pipes enclosed by a jacket holding 115 litres of water. Heat generated by the burner is transferred to the boiler water via the combustion chamber and the flue pipes.

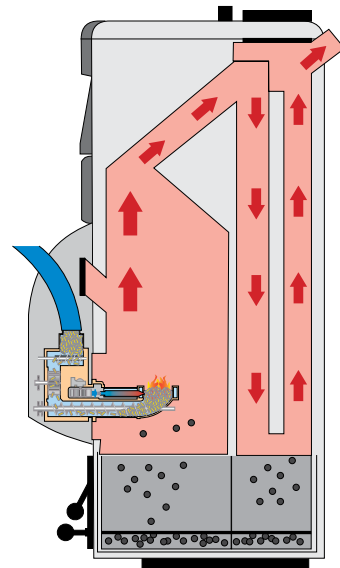

### ■ Small dimensions for easy installation

Thanks to its modest dimensions Biomatic+ 50 can be installed in boiler rooms that would normally be considered too small. Most of the piping connections are placed on top of the boiler. The terminal block for electric installation is accessible from the control panel. Service work is facilitated by the fact that all connections and components are easily accessible from the front. Sweeping takes place through the rebox door or through a cleaning hatch on top of the boiler. Ashes collect in the oversized ash box that is attached to the ash door. The ash box holds 50 litre of ash and is emptied when necessary.

### ■ Hot tap water

The efficient plate heat exchanger (accessory) will ensure that you always get “fresh” hot tap water. A strainer shall be installed in the cold water line to prevent the heat exchanger from becoming clogged (the water quality should be checked).

## ■ SAFETY AND ALARMS

The boiler is designed according to the same main principles as an oil heated system. The advantage of this pelletsystem is easy and comfortable handling, as the location of the fuel store does not depend on the layout of the boiler room. From the safety point of view, the separation of fuel store and burner in combination with interrupted fuel supply between the two means high security.

- In the event of temperature sensor failure, the high-limit thermostat stops operation to prevent the boiler from overheating. The burner automatically resumes normal operation after power failure or interrupted fuel supply.
- Equipment failure leading to operation stop is indicated by a red LED combined with a message on the display panel indicating the cause of the failure. In case of fuel shortage, there is also an audible alarm.
- The boiler design is outstanding with safety as an integral part of the function. As the fuel supply is interrupted and corrected in the burner auger pipe before the boiler wall, there is no continuous fuel line capable of transferring heat outside the boiler wall which means that you do not have to rely on extra safety devices.

*For details about the various alarm conditions please refer to "Troubleshooting".*



The feeder screw is to be placed in relation to the inlet of the burner such that when the tipping chute hangs vertically from the screw it opens out outside of the burner.

### ■ Safety is a natural part of the burner function

Each time filling takes place, only a limited amount of pellets (150 g) is transported through the external feeding system from the storage bin to the top feed connection. To make sure that the correct amount of pellets is supplied from the top feed connection to the burn pot, a separate supply auger has been installed immediately under the top connection controlling the supply of pellets through the air lock and burner auger. As the burner auger is feeding pellets to the burn pot three times as fast as they are supplied, a safety zone containing only a few separated pellets is created between the air lock and the burn pot. This safety zone is always kept intact even in case of power failure, insufficient maintenance or equipment failure. In consequence, safety has become an integral part of the burner functionality.

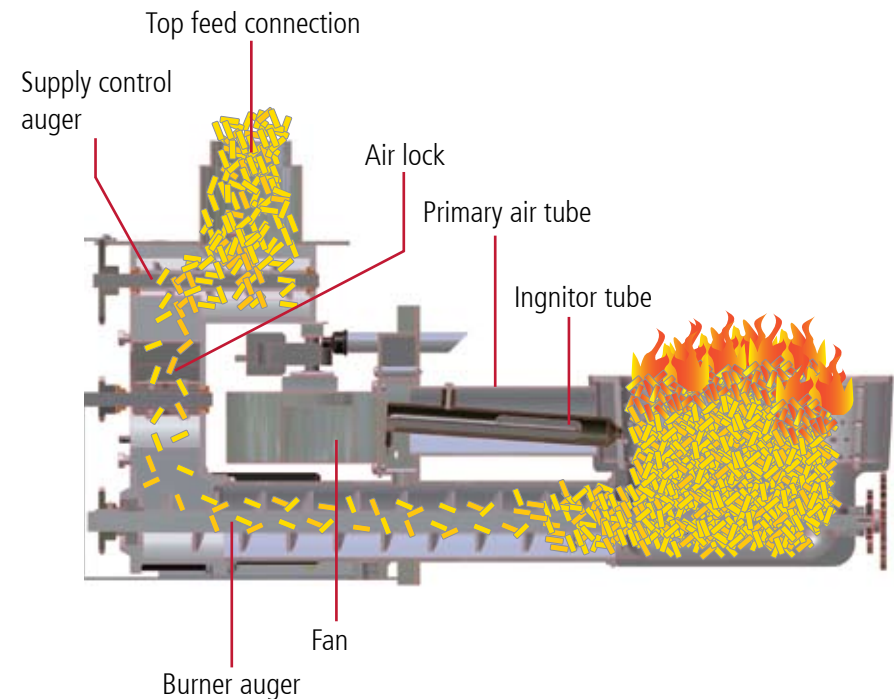

## ■ INSTALLATION

The boiler shall be positioned and installed according to the building rules in force. Before installing the boiler, the chimney must be controlled for underpressure and possible risk of condensation. It is possible that an air draught compensator has to be installed. Inner pipe is recommended for minimizing the risk of condensation. Space needed for installation: Minimum clearance in front of the boiler (burner included) is 1 m. Clearance by the other side of the boiler shall be at least 0,8 m. Minimum clearance on the top of the boiler shall be 0,5 m. The boiler must be level. If the floor is uneven, adjustments can be made with the help of four adjusting bolts (enclosed with the boiler) that shall be fitted to the bottom plate of the boiler. The air intake duct to the boiler room must have at least the same area as the flues.

### ■ Flue connection and combustion air intake

The combination flue of the boiler allows for connection towards the top as well as to the rear. Boiler cement is suitable for sealing. Recommended flue gas requirements: brick chimney lined with a Ø 150 mm acid proof thin-walled tube or an acid proof Ø 150 mm:s element chimney. Recommended underpressure in the chimney is 30 Pa. The height of the gas flue shall be dimensioned according to the building's requirements, but should be at least 6 m. If condensation water comes out of the flue, a condensate drain pan shall be installed in the lower portion of the chimney. The combustion air intake must not be covered.

**ATTENTION!** The chimneysweep must be notified for inspection of the flue.

**CAUTION!** The boiler has low flue gas temperatures, which, under certain conditions, might lead to condensation of flue gases.

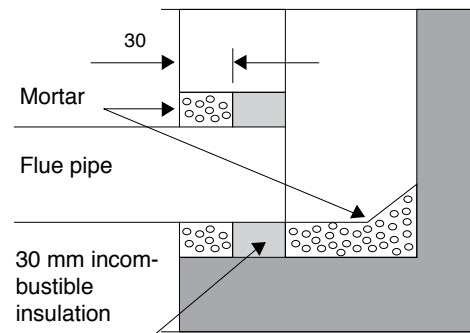

## ■ WATER PIPING

Water piping shall be carried out in accordance with current local and national hot water and building regulations. Safety equipment shall be installed in accordance with regulations in force. If a closed expansion vessel is used, an approved safety valve, a pressure gauge, and a vent valve shall be fitted. The safety valve shall be fitted just above, but not directly on, the boiler in such a manner that the connection with the boiler cannot be closed off. The connecting line from the boiler to the safety valve must rise continuously. Before the boiler is filled with water, the enclosed drain tap shall be fitted.

### ■ Radiator system and expansion vessel

When you fill the system, all valves must be open and the external circulation pump turned off. Bleed the system carefully while filling. When the installation has been in service for a few days, it shall be bled and refilled once again.

**ATTENTION!** See also separate instructions for filling of water.

The volume of the expansion vessel is determined as follows:

#### Open system:

5% of the water volume in the heating system.

#### Closed system:

Select the volume of the vessel in accordance with the manufacturer's instructions.

In the following table, you will find examples of suitable closed system expansion vessels.

System volyme litre*	Opening pressure bar	Initial pressure bar	Vessel volyme in litre	
			70°C	90°C
500	1,5	0,5	35	80
1000	1,5	0,5	80	140
1500	1,5	0,5	80	140
2000	1,5	0,5	140	200

An open system with 500 litre water volume demands at least a 35 litre expansion vessel and a 1500 litre system volume a 80 litre expansion vessel.

\* System volume = boiler volume + storage tanks + piping volume + radiator volume.

## ■ WATER PIPING

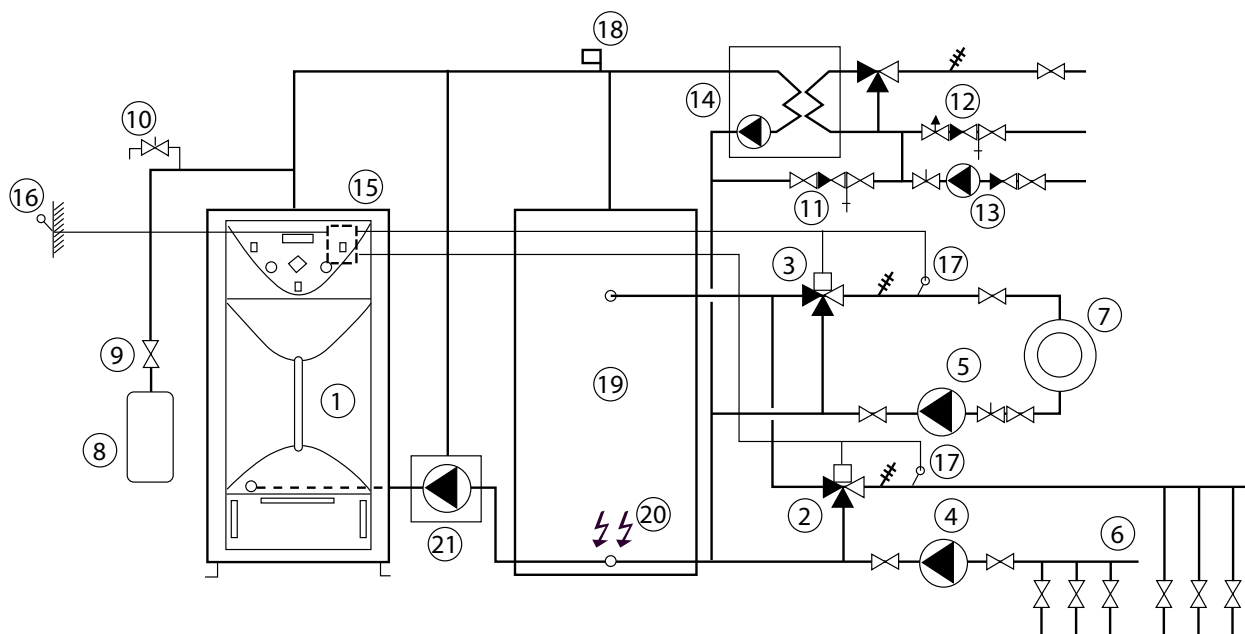

### 1. BIOMATIC+ 50

2. Shunt valve, floor heating (radiator heating)
3. Extra shunt connection, radiator heating (floor heating)
4. Circulation pump, floor heating
5. Circulation pump, radiator heating
6. Floor heating distributor with choke valve and draught check plate
7. Radiator heating circuit
8. Expansion vessel
9. Service valve
10. Safety valve
11. Filler valve
12. Valve pipe with safety valve
13. Circulation pump for drain water
14. Heat exchanger nom. Effect 57 kW
15. Shunt automatic (expansion card, option)
16. Outdoorsensor
17. Outletsensor
18. Automatic air vent
19. Storage tank
20. Heating elements
21. Load unit

### ■ Planning and installation

Planning and installation shall be carried out in a professional manner, attention being paid to general and local rules and regulations. Operating pressure is max. 1,5 bar.

Before taking the installation into service, and always at the beginning of the heating season, the following checks shall be carried out:

- that the heating system is filled and bled
- that the circulation pump is working
- that the system valves are open
- that the automatic control and safety devices are in working order
- that the chimney has the necessary draught and that the fresh air ventilation is open.

### ■ Safety valve

If a closed expansion vessel has been installed in the radiator system, the safety valve must be checked 4 times a year. Activate the valve by pressing or turning the control button and check that water escapes from the overflow pipe connecting the valve to the drain.

## ■ FILLING OF WATER

Before you begin heating, the heating system must be filled with water.

To fill the system, do as follows:

1. Open all shut-off valves, including the shunt valve. The pump must be switched off.
2. Fill the boiler and the radiator system with water. Bleed the system at the radiators.
3. Once the system is filled completely, the circulation pump can be started and heating can begin.
4. When the boiler water has reached its pre-set operating temperature, the pump should be stopped and the system bled at the radiators once again. This should be repeated several times.

Remember that much air is enclosed in tap water. The enclosed air volume may reach as much as 10%, which explains why bleeding takes time – especially where there are large water volumes. A closed system shall be filled until the pressure gauge indicates the correct system pressure, i.e. the distance from the pressure gauge to the highest radiator in meter times 0,1 which gives the system pressure in bar.



## ■ START-UP IN OFF MODE

### ■ Start-up in OFF mode (cold burner start with electrical ignition)

You can only start up in this way when the burner has been switched off at the control panel or when the power is restored after a power cut. The boiler temperature must be 8 degrees below its set-point value.

**Attention!** When the boiler is started for the first time after installation this must be done by an authorised installer.

- If the external feed system has been emptied of pellets, it must be refilled before you can start. The easiest way to refill the system is to remove the filling hose from the burner top coupling letting it hang freely over a container. Switch on the power to the burner control unit so that the operation indicating light is red. Operating mode shall be OFF. Scroll through menu 1 with the arrow-forward key until you reach EXTERNAL AUGER MANUAL and time (15 min). Start the external auger by pressing the plus-key. Remaining operating time is indicated on the display panel. The external auger can be stopped with the minus-key before the programmed time has elapsed.
- To start the burner, scroll through menu 1 with the arrow-forward key until you reach ON/OFF. Select ON with the pluskey. This starts the motor of the burner auger feeding fuel to the burn pot. After another 3 min the fan and ignition element will become activated. When the fuel level has reached about the height of the ignition element's hot air outlet, the feeding rate will be reduced and after a total of some 6-7 minutes the pellet fuel will ignite.
- The boiler's optical monitor detects when the fuel has ignited and switches off the ignition element. The red light goes out and the green comes on to confirm that the burner is operating. Fan speed is reduced. At the same time the fuel feed motor stops for three minutes to allow all the pellets in the burn pot to ignite. After that pellets will be fed at reduced speed for another 5 minutes. After a subsequent wait time of 10 minutes, the burner control cuts in and controls the operation of the burner. If ignition fails, this is indicated by red light and an alarm message on the display panel.

**Attention!** Sometimes, when the burner is started for the first time, or if there are no pellets in the burner, a fire-start might be necessary after some 3 minutes operation. It is always possible to light the fuel manually using fire-lighting fluid.

## ■ START-UP IN OPERATING MODE

### ■ Start and stop in operating mode

The green LED indicates that the burner is in operating mode.

During operation, start and stop is regulated by the boiler temperature sensor. When the water temperature falls to 5 degrees below its set-point value, the burner starts in the programmed low power mode. If the water temperature falls by an additional 2 degrees to 7 degrees below the set-point value, the programmed high power mode is activated. The burner will then operate in this mode until the temperature has risen to 4 degrees below set-point value when it returns to low power mode. When the burner is working, the green LED is lit. A red light indicates that the burner is not in operation (see "Troubleshooting")

### ■ OFF

To switch on the burner open menu 1 and go to ON/OFF using the arrow-forward key. Select OFF using the minus key. When the burner is switched OFF, a red light is lit on the control panel to indicate that power is connected.

**Attention!** Always switch off the power to the burner during service work.

## ■ SETTINGS

### ■ Adjusting combustion

The boiler is delivered with factory settings, which in most cases are sufficient for proper, efficient combustion. The boiler's factory settings can be applied if negative pressure is 30 Pascal (Pa) in the flue. If combustion is poor anyway and the flue gases from the chimney are black or the ash is grainy, combustion can be adjusted to attain the desired end results. Adjustment is made with a flue gas analyser and should be carried out by a service technician authorised by Aritem. Flue gas analysis shall be shown for carbon monoxide (CO) values under 200 ppm and excess air (O<sub>2</sub>) 6-8%.

The fan's air quantity and the feed percentage for the burner screw is adjusted in the following manner.

The amount of pellets in the burner cup is set in the output menu by changing the percent figure for POWER HIGH AUGER and POWER LOW AUGER.

The amount of air is set in the output menu by changing the percent figure for POWER HIGH FAN 1 and 2 POWER LOW FAN 1 and 2.

#### POWER MENU

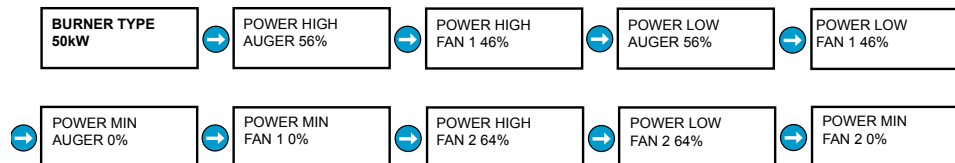

## ■ BURNER OVERVIEW

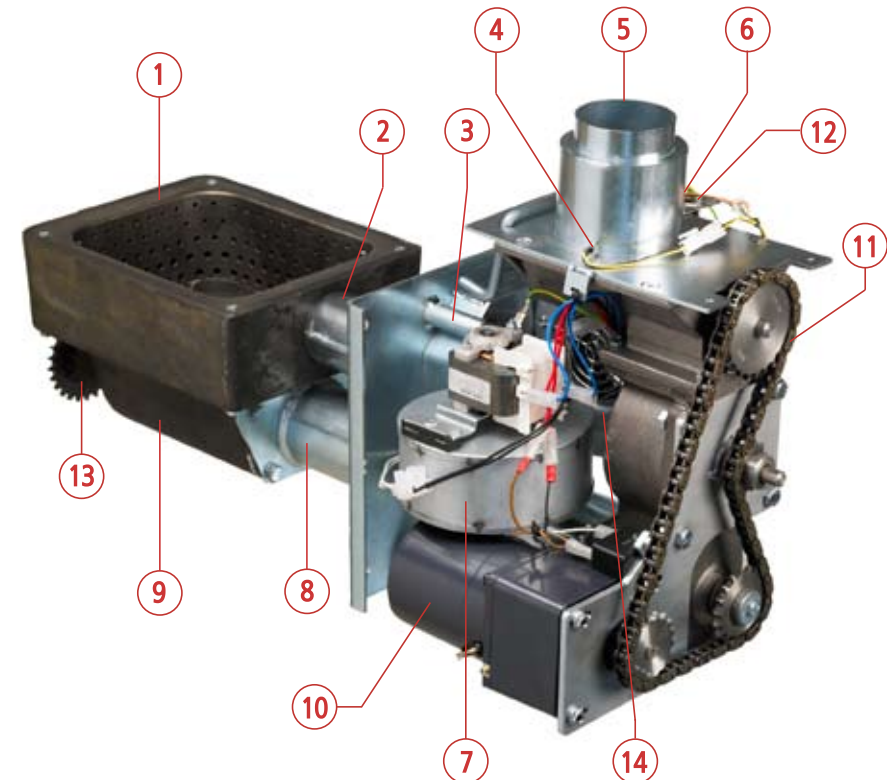

- |                               |                       |
|-------------------------------|-----------------------|
| 1. Primary air ring           | 8. Auger tube         |
| 2. Primary air tube           | 9. Burn pot           |
| 3. Optical monitor tube       | 10. Auger motor       |
| 4. Level monitor, receiver    | 11. Chain             |
| 5. Top coupling               | 12. Connector panel   |
| 6. Level monitor, transmitter | 13. Burn pot screws   |
| 7. Primary air fan            | 14. Secondary air fan |

## CONTROL PANEL

1. Fuse, circulation pump hot water circuit (not in boiler's inner structure)
2. Fuse, circulation pump external heating circuit
3. Switch, circulation pump hot water circuit (not in boiler's inner structure)
4. Switch, circulation pump external heating circuit
5. Overheating protection, burner. Reset button for high limit thermostat
6. Control unit function keys. See chapter "Control Panel Layout"
7. Green indicating light. Is on when the burner is in operation mode.  
Red cause-indicating light. Is on when the burner is switched off or has stopped.  
A message describing the cause is shown on the display panel.  
Flashing red/green cause-indicating light. Indication for programmed reminder alarm. Does not stop operation
8. Display panel for messages. Display of operating mode, alarm messages, system settings
9. On/Off switch. Main switch for pellet burner
10. Connection for external auger

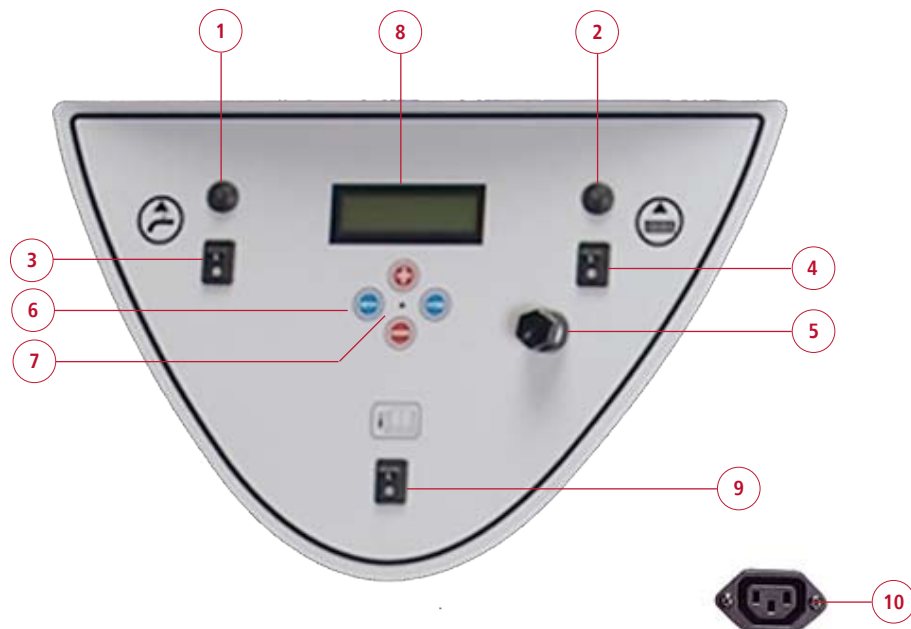

## CONTROL COMPUTER AND MENUS

### Default Settings

The settings made at the factory cover most of the control system functions. Normally only the following adjustments have to be made.:

1. Selection of operating mode (heat source)
2. Adjustment of set-point value for boiler temperature (desired temperature of boiler water).
3. Programming of desired value for reminder alarm.

### Service Levels

The control unit has different menu levels for the adjustment and viewing of the control system parameters. The tables on pages 15-16 will give you a detailed description of the menus shown on the control unit display panel. Normally the control unit is at menu level 1.

To reach menu level 2 "Service", do the following:

- Press arrow forward and arrow backward at the same time for 5 seconds.  
The message "Service" is shown on the display panel. The control unit is now at the service menu.
- Move forward in the service menu by pressing "arrow forward".

If you do not press any of the control keys, the control unit will revert to menu 1 automatically after 8 minutes. There are two more service levels, but they are reserved for the service technician only.

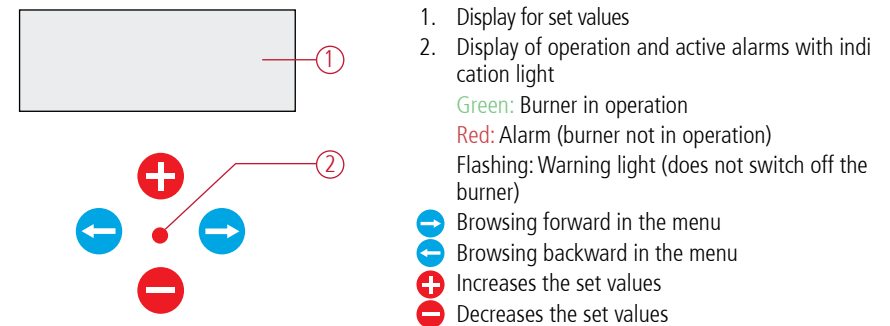

1. Display for set values
  2. Display of operation and active alarms with indication light  
Green: Burner in operation  
Red: Alarm (burner not in operation)  
Flashing: Warning light (does not switch off the burner)
- Browsing forward in the menu
  - ← Browsing backward in the menu
  - + Increases the set values
  - Decreases the set values

## ■ DISPLAY MESSAGES AND POSSIBLE ADJUSTMENTS

The following tables give an overview of the messages, which may appear on the display of the control unit. They also indicate which parameters the user is allowed to change, and which parameters are allowed to be changed only in case that the user has been given instructions from an authorised installer. Note that a part of the menu options are displayed only when they are activated.

### ■ Description of level 1 menu ->

Text on the display	Description	Setting possibilities
Temperature boiler xx (80) °C	Boiler temperature, set value in brackets. Shows the actual temperature of the boiler, the set value shows the desired temperature.	Adjustable between 20 and 95°C by means of the Plus and Minus buttons.
ON (OFF)	Operating mode. In ON mode the burner switches on when needed. In OFF mode the next menu displays "Auger external manual".	Selectable by means of the Plus and Minus buttons.
Operation mode, pellet (The menu is displayed only when the electric resistors are activated)	Options: <ul style="list-style-type: none"> <li>• pellets</li> <li>• electric (not available in Biomatic+ 50)</li> </ul>	Selectable by means of the Plus and Minus buttons.
Operation mode	OFF, start, stop, temperature hold, max, medium, min, electric. This menu also displays the different starting stages.	For information only.
Temperature flue gas	Flue gas temperature	For information only.
Operating time press plus key	Press the Plus button and then the arrow button "forward" to the next screen, if you want to view the operating time data.	The operating time is reset by pressing the Plus and Minus buttons simultaneously for 3 seconds.
Operating time total	Total operating time of the burner.	
Operating time high	Operating time at high power.	
Operating time low	Operating time at medium power.	
Operating time min	Minimum power level during operating time (only displayed when the min operating level is activated)	
Operating time electric el1	Operating time of the resistor 1	(not available in Biomatic+ 50)
Operating time electric el2	Operating time of the resistor 2	(not available in Biomatic+ 50)
Pellet store press plus key	Press the Plus button and then the arrow button "forward" to the next screen, if you want to view the pellet store data.	
Estimated time left	Displays the number of operating days at the average consumption level in question.	For information only.

Text on the display	Description	Setting possibilities
Pellet store	Displays the amount of pellets in the store, a new figure can be entered in connection with reloading the pellets store.	For information and can be changed.
Feeding factor	Displays the feeding power of the external auger	Adjustable between 0 and 76.7 kg,
Consumption average	Displays the average consumption during the last 8 days.	For information only.
Consumption total	Displays the total consumption of pellets.	For information only.
Auger external total	Displays the total operating time of the external auger in hours	For information only.
Alarm pellets min	Sounds an alarm for calculated set minimum amount of pellets in the store.	Adjustable between 0 and 3.0 tons.
Service press plus key	Press the Plus button and then the arrow button "right" to the next screen, if you want to view the service menu.	
Alarm ash removal	Sounds an alarm for emptying the ash box upon reaching a set value.	Adjustable between 0 and 250 h, according to the operating time of the external auger.
Alarm cleaning	Sounds an alarm for cleaning of the combustion head upon reaching a set value.	Adjustable between 0 and 250 h, according to the operating time of the external auger.
Flue gas max °C	Audible alarm for cleaning of the convection parts upon reaching a set value	Adjustable for alarm "max value" between 120 and 280°C

## ■ DISPLAY MESSAGES AND POSSIBLE ADJUSTMENTS

### ■ Description of menu 2 – Service

**Service:** To select this menu press both arrow buttons simultaneously for. approx. 5 seconds, then press the arrow button forward to the next screen.

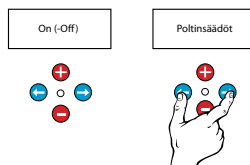

Text on the display	Description	Setting possibilities
El Step	Displays in brackets the activation of one of the electric resistors <i>(not available in Biomatic+ 50)</i>	To activate one of the electric resistors enter number (3) here by means of the Plus button.
Start backup heat 15°C	Displays temperature difference from the target temperature, at which the electric resistor is switched on <i>(not available in Biomatic+ 50)</i>	Adjustable between 10 and 40°C.
Level monitor	Measured light intensity in percentage. The set limit value for the light in brackets in percentage.	Adjustable between 10 and 90%.
Optical monitor level	Measured light intensity in percentage. The set limit value for the light in brackets in percentage.	Adjustable between 1 and 98%.
Test outputs press plus key	Press the Plus button and then the arrow button to the right, if you want to view the test values.	
Auger external	0/1 manual test.	Enabled by pressing the Plus button, disabled by pressing the Minus button.
Fan	0 to 100%	Enabled by pressing the Plus button.
Auger burner	0/1 manual test.	Enabled by pressing the Plus button.
Ignition	0/1 manual test.	Enabled by pressing the Plus button. Note: the test is performed only when the fan is running.
Alarm	0/1 manual test of the alarm diode.	Enabled by pressing the Plus button.
El Step	0/1 manual test <i>(not available in Biomatic+ 50)</i>	Enabled by pressing the Plus button.
Power	0	See the next menu.
English	Selection of the display language.	Finnish, Swedish, English, German or Italian can be selected by pressing the Plus/Minus buttons.
Address	0	Not used.
Default set vXXXX	Displays the version number of the processor and enables resetting the factory settings.	The factory settings can reset by pressing the Plus button.

### ■ Description of menu 3 – Power

**Power:** In order to activate this menu, select number 5 in the “Service” - “Power” menu by pressing the Plus button. Wait, until the number stops flashing and continue by pressing the arrow button to the right.

Text on the display	Description	Setting possibilities
Power	0	The menu is activated by entering code 5. Wait, until the number stops flashing and continue by pressing the arrow button to the right.
Burner type	50 kW <b>Note: Don't change the factory setting, button -&gt; resets the original settings.</b>	50 kW
Power high auger	Setting of fuel feed to high power (%).	50 to 100%, adjusted by means of the Plus/Minus buttons. Note! The maximum value is 90% for 20 kW.
Power high fan	Setting of speed of the fan to high power (%).	1 to 100%, adjusted by means of the Plus/Minus buttons.
Power low auger	Setting of fuel feed to medium power (%).	1 to 100%
Power low fan	Setting of speed of the fan to medium power (%).	1 to 100%, adjusted by means of the Plus/Minus buttons
Power min auger	Setting of fuel feed to low power (%).	1 to 100%, not in use at level 0.
Power min fan	Setting of speed of the fan to low power (%).	1 to 100%, adjusted by means of the Plus/Minus buttons.
Power high fan 2	Setting of speed of the fan to low power (%).	1 to 100%, adjusted by means of the Plus/Minus buttons.
Power low fan 2	Setting of speed of the fan to low power (%).	1 to 100%, adjusted by means of the Plus/Minus buttons.
Power min fan 2	Setting of speed of the fan to low power (%).	1 to 100%, adjusted by means of the Plus/Minus buttons.
Cleaning fan	Frequency of cleaning blows	0 to 4 blows/h.
Holding time	Time between maintenance periods for the glow of embers	20 to 120 minutes, in increments of five minutes, adjusted by means of the Plus/Minus buttons.
Auger external time	Setting of operating time for the external auger.	1 to 250 seconds.
Auger external t manual	Setting of operating time for the external auger in manual operation.	3 to 60 minutes, adjusted by means of the Plus / Minus buttons.
Hot starts burner	Displays the number of hot starts.	Is reset by pressing the Plus/Minus buttons simultaneously for 3 seconds.
Cold starts burner	Displays the number of cold starts.	Is reset by pressing the Plus/Minus buttons simultaneously for 3 seconds.

# ACTIONS CHART

## ACTIONS CHART Biomatic+ 50 / BeQuem 50 version 0906

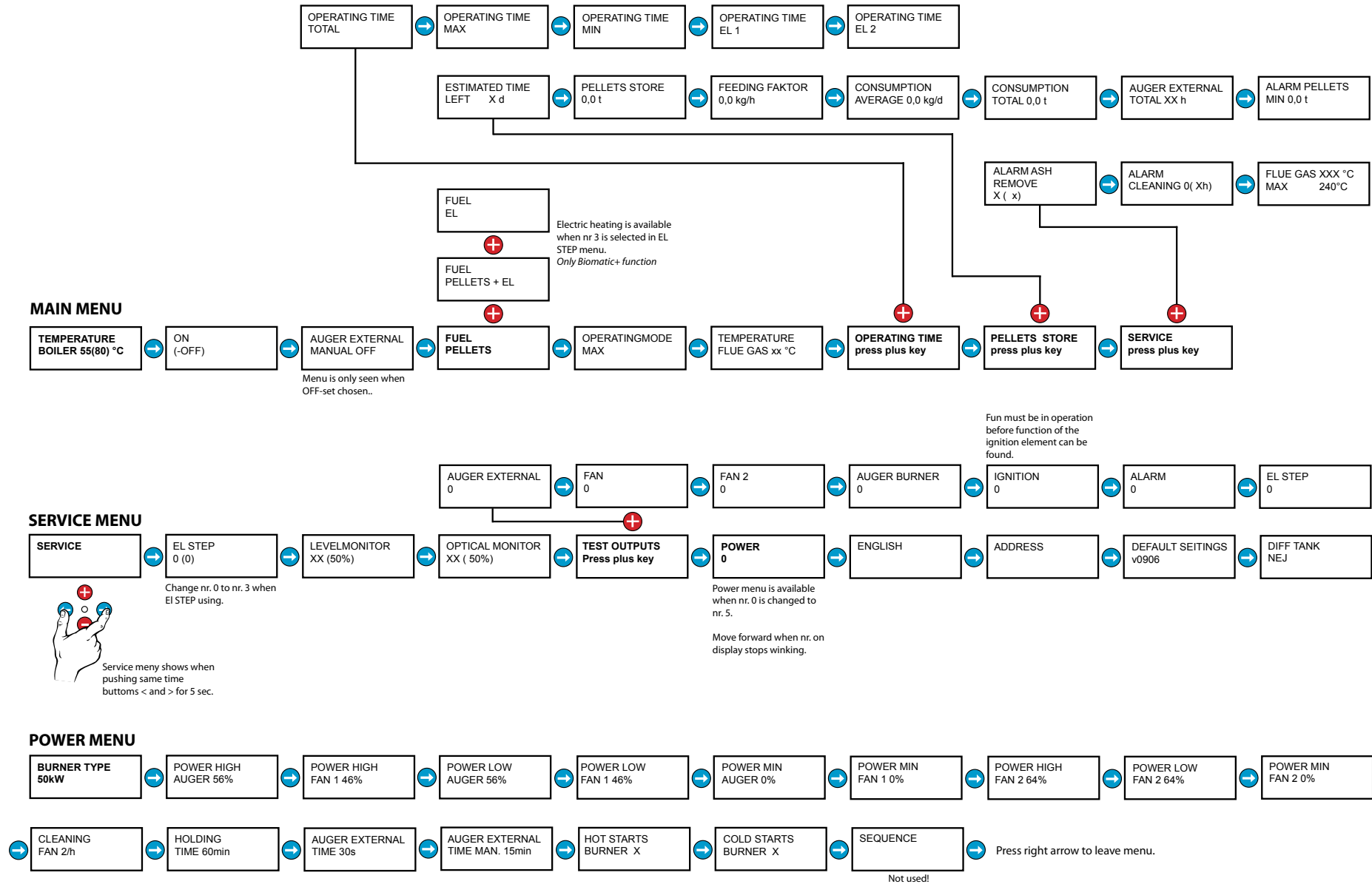

## ■ TROUBLESHOOTING

In case an alarm becomes active, this is indicated on the display of the control panel with a red light and a text message. This facilitates troubleshooting, because the user can see the cause of the problem. The alarm is acknowledged by selecting OFF on the control unit. The cause of the alarm must always be determined and the problem removed before the device is switched on again.

The following checks and remedies are described in such an order that the most probable cause of the problem is given first.

Problem	Check	Remedy
All display segments are out.	that the fuses of the control unit of the burner are intact and the main switch has been turned ON. has the over-temperature protection tripped?	Replace the defective fuse in the control unit or turn ON the power by means of the main switch. Note! Disconnect the device from electricity supply before replacing the fuse. The size of fuses F1 and F2 is 4A/230 V. If the cause of over-heating cannot be determined with certainty, contact an authorised technician. If the over-temperature protection of the boiler has tripped, put it back into operation by pressing the RESET button. After this switch the control unit OFF and then back ON. Also check that the 3-phase current is correctly connected.
The red operation indication is on. The display reads: <b>ALARM PELLETS NO.</b> The burner is requesting fuel, but has not received it.	that there are pellets in the fuel storage.	Add pellets.
	that the inclination of the drop pipe is not too gentle.	Shake the drop tube and change the inclination so that pellets will not get stuck.
	that the inclination of the external auger is not too steep (max 45°) or feeding of fuel has not stopped, because pellets have been stuck in the silo.	Adjust the auger into a more gentle angle and turn it back and forth a few times so that the pellets come loose. The feed opening of fuel must be located in the middle of the fuel store (applies to small week stores).

Problem	Check	Remedy
	that the motor shaft rotates the auger and the motor of the external auger operates. (In most cases the default setting of the operating time of the external auger (30 seconds) is not long enough to bring sufficient amount of pellets to the burner. If the problem cannot be removed by means of the above checks and remedies, the operating time of the external auger may be too short. In such cases increase the operating time (see page 15, menu 3 -> "Auger external time"). However, the operating time must not be so long that pellets accumulate into the drop tube.)	If the motor does not rotate, disconnect the power cable from the boiler and connect it directly to a mains socket by means of the additional cable provided. If the motor has been over-heated due to a blockage or for some other reason, the over-temperature protection of the motor may have been tripped. The motor will not start until it has been cooled down. Also check that there are no blockages in the auger.  If there are problems with the motor, contact an authorised technician.
The red operation indication is on and the display reads: <b>ALARM MAX THERMOSTAT</b> , or <b>ALARM MAX THERMOSTAT ELECTRIC</b> The over-temperature protection of the boiler has tripped.	has the over-temperature protection tripped? check the circulation pump.	If the cause of over-heating cannot be determined with certainty, contact an authorised technician. If the over-temperature protection of the boiler has tripped, put it back into operation by pressing the RESET button. After this switch the control unit OFF and then back ON. Also check that the 3-phase current is correctly connected.
The red operation indication is on and the display reads: <b>CONTROL EL. IGNITION</b> or <b>CONTROL OPTICAL MONITOR</b> The cause of the problem is that the optical flame monitoring of the burner has not detected flame during a certain period of time. No fuel has entered into the combustion head.	that the flame guard and/or the combustion head is not full of ash and the flame guard has not over-heated or sooty.	Remove ash, clean the combustion head from loose ash and wipe the flame guard clean. If the flame guard becomes easily sooty, the cause may be incorrect settings or too low under-pressure in the furnace. In such cases call a technician.

## ■ TROUBLESHOOTING

Problem	Check	Remedy
	The device has been stopped during a hot start.	Check that the pellets fed into the combustion head are whole. The fuel consists of pieces, the burner cannot keep up the embers. The reason for recurring stops may also be an excessive play in the blocking feeder, which makes it difficult to keep up the embers.
	The device has been stopped during a cold start.	Check the function of the ignition resistor, unless ignition does not succeed after two start attempts.  If the cause of the operation cannot be determined with certainty or the ignition resistor must be replaced, contact an authorised technician.
The red operation indication is on and the display reads: <b>ALARM LEVEL MONITOR</b> , or <b>ALARM BLOCKAGE</b>  The cause of the problem is that the optical flame monitor of the burner has not detected light during a certain period of time. No fuel has entered into the combustion head.	is there fuel in the upper connection?	If there is no fuel in the upper connection of the burner, check the cable connections of the level switches. If this does not help, wipe the level switches clean. If the external feed of the burner does not start in spite of this or the level switches must be cleaned continuously, they may be defective and, when necessary, should be replaced by an authorised technician.

Problem	Check	Remedy
	that the feed auger, blocking feeder and burner auger rotate and are not blocked, e.g. because of a foreign object.	A possible foreign object in the pellet fuel must be removed, if it gets stuck in the blocking feeder or in one of the feed augers. Remove the upper connection and take out the possible foreign object from the feed auger or blocking feeder. In connection with the inspection of the burner auger remove the four augers located between the inner and middle part and pull out the burner auger from the tube. Be sure to disconnect all cable connections.

## ■ MAINTENANCE, CARE, SWEEPING

### ■ Boiler cleaning

Burning solid fuels, even if operation is automated, normally calls for a little more care and maintenance than oil heating. For Biomatic+ 20/30 maintenance has been minimized as the result of well planned design and a big ash box holding 50 litres.

Ash is removed when necessary. The convection parts of the boiler are to be cleaned when the flue gas temperature has risen by 20-30°C above the temperature of a newly swept boiler. An alarm reminding you of cleaning can be programmed on the control panel.

**ATTENTION!** Pay special attention to the pellets quality when you receive a new delivery or when you change supplier.

**ATTENTION!** Show a great care when emptying the ash as it might be glowing hot. Ash must be kept in a fireproof container.

### ■ The burner

Carry out checks and measures when needed or in connection with boiler cleaning according to the following:

- Normally, the burn pot does not demand any particular care, but should be checked for carbon build-up in connection with ash removal. If necessary scrape off any carbonisation.
- Put the burner back into place - check carefully that no sealing is damaged.

### ■ Once a year to once every second year

- Clean the primary ring and primary air tube on the inside to remove dust and chips. Check the pins of the metering wheel, the toothed wheel and the back stop for wear. Adjust and replace if necessary. Lubricate the driving chain with a little thin oil.

When new pellet fuel is used, always check the burn pot for sintered ashes (crust of ash or gravel and stone-like particles). Such particles must be removed from the burn pot at very short intervals to prevent the primary ring from getting overheated and damaged. Sintering is caused by impurities in the pellet fuel and a claim should be sent to the supplier at once.

*For more information please refer to "Advice about Fuel Pellets".*

## ■ MAINTENANCE, CARE, SWEEPING



Cleaning the convectional flues. Lift the sweeping hatch at the top of the boiler and clean the flues with brush. Cleaning is needed few times a year.

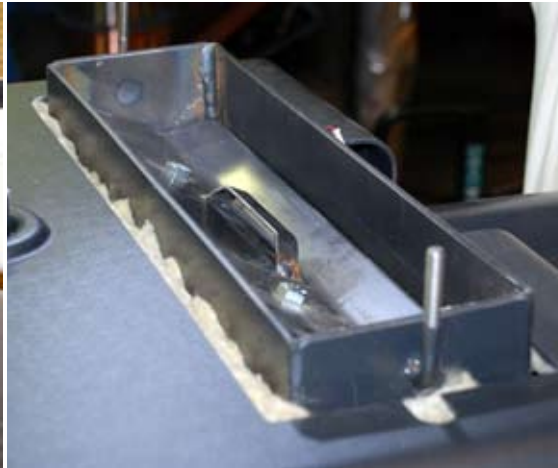

Check the position of the hatch before removing it.



Remove the hatch.



Cleaning brush is included in Ariterm pellet boiler delivery. Move the brush through the flues to sweep the ash from flue walls.



Ash compression lengthens the interval between emptying the ash. The ash tightens when the adjuster is moved back and forth.



Emptying the ash. Pull out the ash box. Empty the ash into a decked fire-proof container outdoors. Because of the fire risk, the container must not include anything but ash.

## ■ MAINTENANCE, CARE, SWEEPING

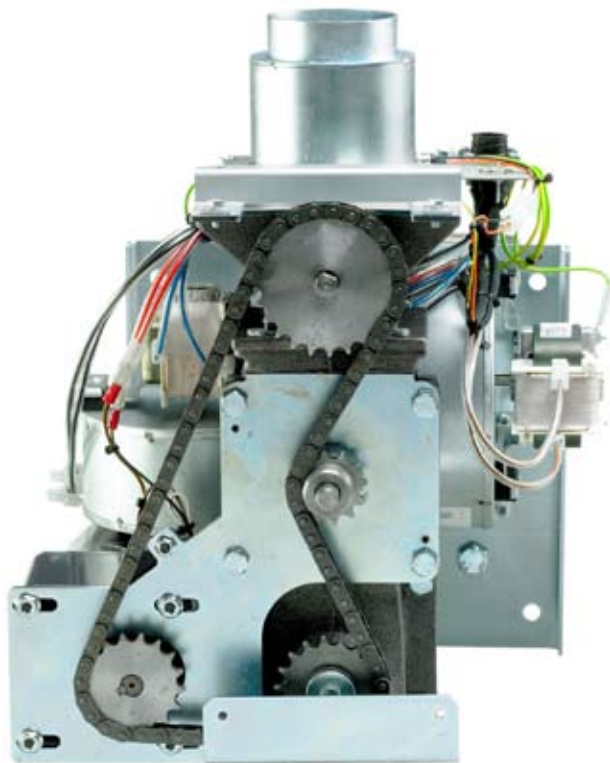

CHECK THE CONDITION OF THE CHAIN AND WHEELS REGULARLY. CHANGE WORN OUT PARTS WHEN NECESSARY.



THE BURNER CUP AND THE SCREWS WITHIN THE CUP MUST BE CAREFULLY CLEANED TO ENSURE FLAWLESS OPERATION.

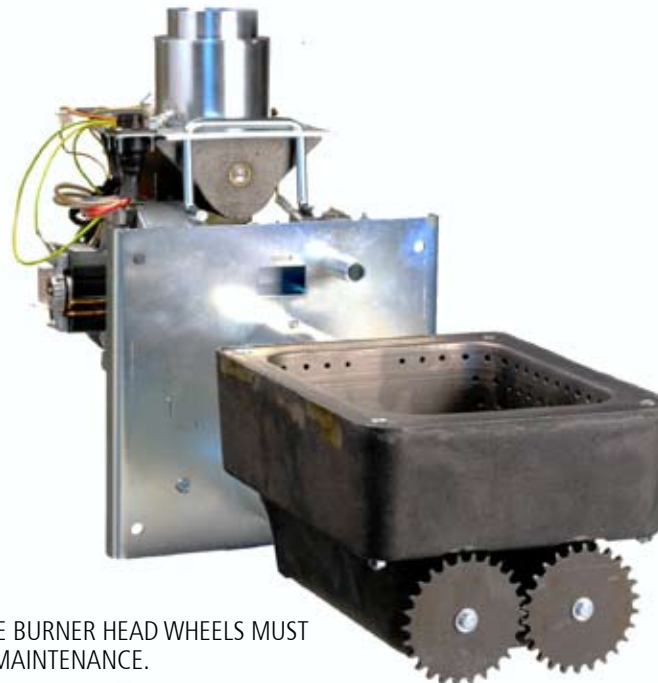

THE CONDITION OF THE BURNER HEAD WHEELS MUST BE CHECKED DURING MAINTENANCE.

## ■ Cleaning of Flame Control



PULL THE FLAME CONTROL SENSOR GENTLY OUT OF THE PIPE.



CLEAN THE FLAME CONTROL SENSOR.



CLEAN THE FLAME CONTROLLER METAL PIPE SO THAT THE ASH IN THE PIPE WILL NOT HINDER THE OPERATION OF THE FLAME CONTROL SENSOR.

## ■ ADVICE ABOUT FUEL PELLETS

- Pellet fuel can be manufactured from several different biologically derived raw materials. Most common is wood, but today there are several alternative materials available on the market that are suitable for pellets manufacture. These raw materials have various characteristics that can be advantageous or disadvantageous for pelletised fuel. Important factors that can be assessed are energy content, size, amount of fines, moisture content and, last but not least, the price. We recommend that you choose the fuel that has the lowest cost per energy unit after checking how the fuel performs in the burner. Study carefully the fuel performance after new delivery. In case of doubt, please contact us at Ariterm.
- Most of the problems that arise on account of inferior fuel quality are the result of inadequate handling and storage before the fuel reaches the end customer. If the fuel has high fines content the problem is usually due to separation during storage or loading. The formation of sintered ash is due to silicate contaminants (sand). These cannot be discovered before they are used. If you get pellets that produce sintered ash, a claim must immediately be sent to the pellet supplier.

**ATTENTION!** If sintered ash is formed, the burn pot must be continuously cleaned of sintered material (with a table spoon for example).

- Damp pellets can be the result of inadequate handling and transport. If possible, inspect the pellets before they are unloaded to make sure that you get clean and dry pellets and no fines.

**ATTENTION!** Damp pellets must be rejected immediately.

FUEL RECOMMENDATION	
Raw material	Chemically untreated barkless wood
Diameter	8 mm
Length	15 to 32 mm
Volume weight	over 600 kg/m <sup>3</sup>
Moisture content	less than 10 %
Ash content	less than 0.7 weight %
Fine material content	max 4 weight %
Melting temperature of ash	less than 1000 °C
Energy content	> 4,75 kWh/kg

## ■ STORAGE PLANNING / GUARANTEE

When planning the pellet store you should keep in mind that you cannot use the same feeding system for a store designed for a day's or a week's supply as for a store designed for bulk deliveries.

A common way is to start with a small and simple pellet store which is a quick and simple solution. It demands a bit of handling however, both when you pick up the pellets from your supplier and when you fill them into your store. For this kind of store, pellets can be acquired in small sacks (normally between 6-20 kg) or large sacks (normally between 500-1000 kg).

The very best solution for a convenient and simple handling of pellets however is to install a pellet store designed to accommodate pellets delivered by bulk tanker. This delivery method will demand a store of some 6 m<sup>3</sup> to accommodate 3 tons which is the normal volume at bulk deliveries.

The pellet store should be designed to eliminate the risk of contamination and moisture penetration. Take special care to avoid damp penetration through the walls and floor. It is also important that pellets are not exposed to direct contact with water in the form of rain or condensation. Pellets do not however absorb moisture from surrounding moist air and can therefore be stored outdoors as long as they are under cover.

The fuel store should be planned according to your estimated consumption so that refilling and handling takes place at convenient intervals.

### ■ Guarantee

This boiler manufactured by Ariterm AB is guaranteed to be free of defects in workmanship and materials for a period of 24 months (2 years) from the date of installation. The manufacturer shall not be held liable for faults caused by incorrect installation, incorrect use, freezing, over-temperature or over-pressure. Any attempts made to repair the product without the manufacturer's permission or if the guarantee card has not been returned to the manufacturer, will invalidate the guarantee. The manufacturer shall not be held liable for any possible indirect damage and/or financial loss caused by the boiler.

Ariterm AB reserves the right to decide the method how a possible guarantee repair is carried out. Ariterm AB is not liable for damages occurred after the expiration of the guarantee period, but compensation for such incidents may be agreed upon separately case by case.

## ■ FEEDING SYSTEM DEPO / FEEDO

### ■ Depo

The Depo discharge chute is a patented transport solution that efficiently, functionally and at a low noise level feeds pellets from storage via a conveyor to the burner. The Depo is particularly appropriate in combination with the Feedo screw conveyor.

### ■ Feedo

The Feedo screw conveyor provides safe, problem-free transport of pellets between storage and the burner. The Feedo is particularly appropriate in combination with the Depo discharge chute.

**NOTE!** Installation of Depo / Feedo, see separate manuals for each product.

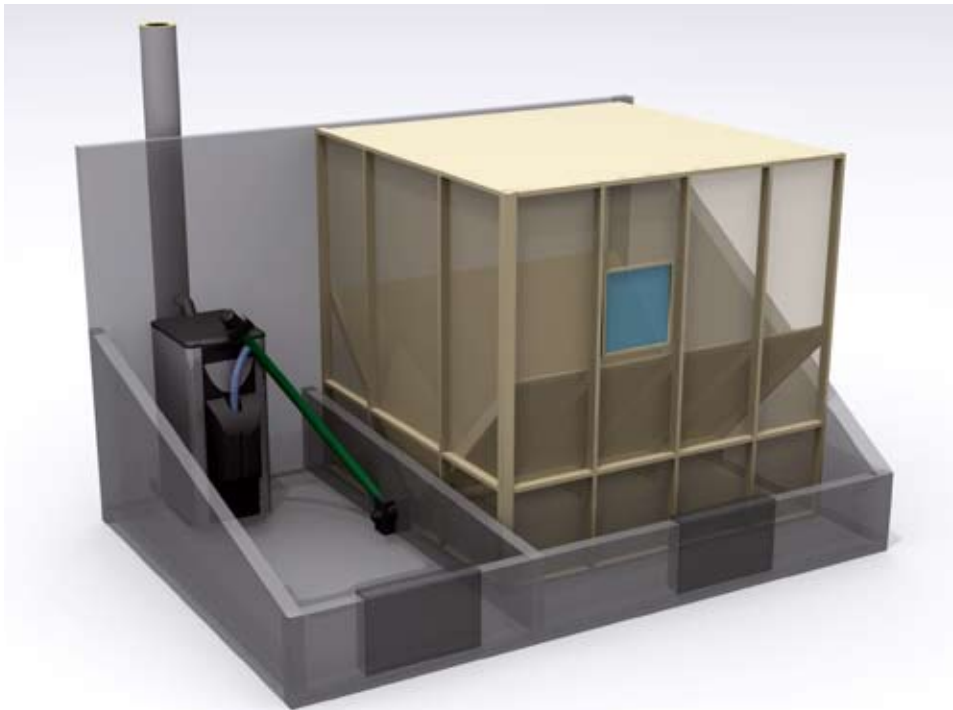

■ FEEDING SYSTEM DEPO / FEEDO

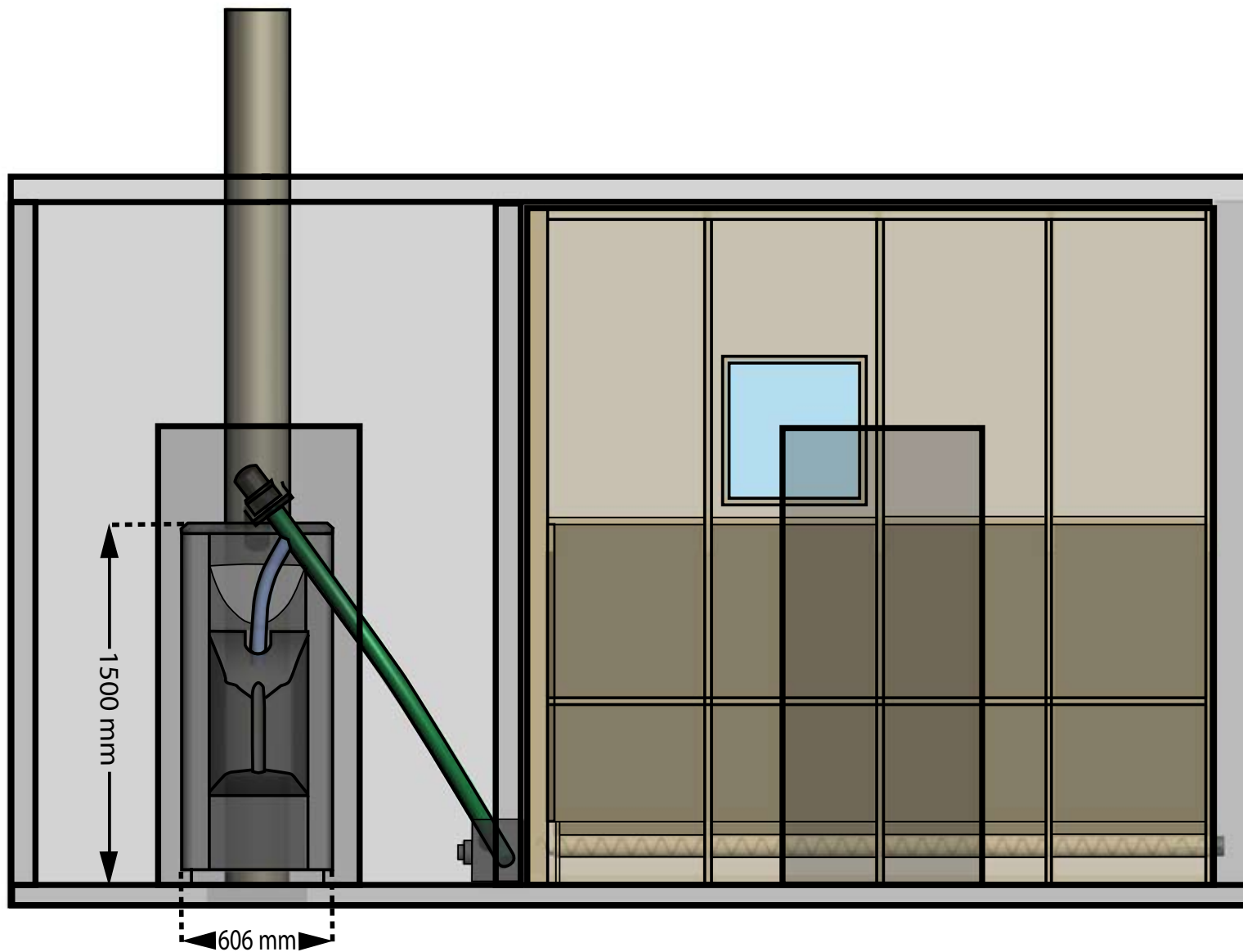

■ FEEDING SYSTEM DEPO / FEEDO

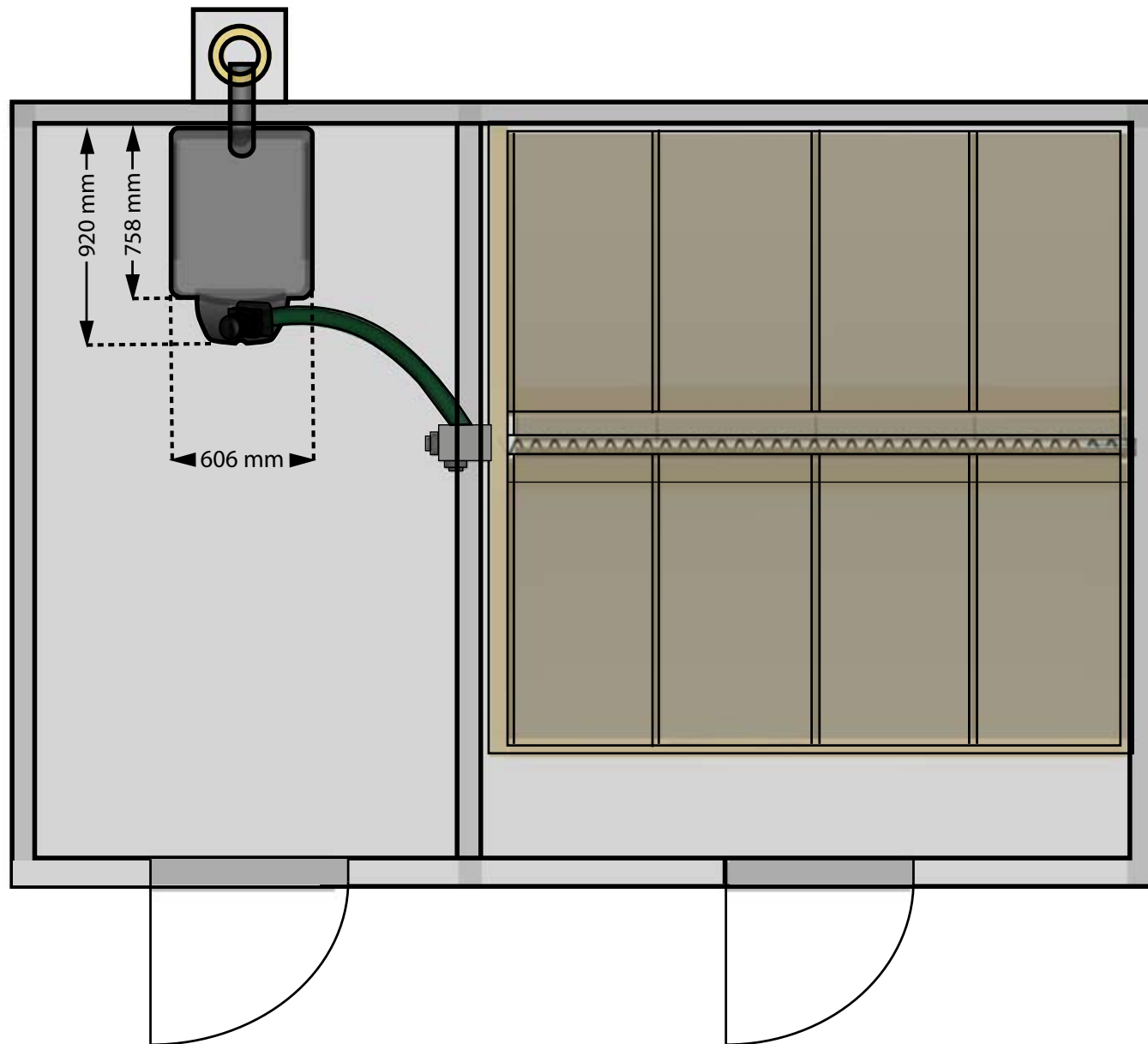

## VAATIMUSTENMUKAISUUSVAKUUTUS



Valmistaja: ARITERM OY  
Osoite: PL 59, 43101 SAARIJÄRVI

Laite: **Biomatic+ 50 pelletilämmityskeskus**

Valmistaja vakuuttaa,

- että tämän yksikön kattilaoosan valmistuksessa on huomioitu Euroopan yhteisön neuvoston painolaittedirektiivin (97/23/EY) olennaiset turvallisuusvaatimukset. Vaatimustenmukaisuuden arviointimenettelyinä on käyretty H - moduulia. (Ilmoitettu laitos 0424)
- että poltinosaan valmistuksessa on noudatettu oheisten direktiivien vaatimuksia:  
EMC-direktiivi 89/336/EEC, pienjännitedirektiivi 73/23/EEC ja koneidirektiivi 98/37/EC
- seuraavia standardeja on sovellettu:  
EN 303-5 ( luokka 3 )  
LVD: EN 60335-1, EN 50165:1997-06-27, EN 50165/C1:1998-04-24, EN 50165/A1:2001-04-20  
Koneidirektiivi: EN 292-1, EN 292-2  
EMC: EN 55011B, EN 55014, EN 55014-2, EN 61000-3-2, EN 61000-3-3, EN 6000-4-2, EN 6000-4-3, EN 6000-4-4, EN 6000-4-5, EN 6000-4-6, EN 6000-4-11, EN 61000-6-2, EN 61000-6-3:2001

## DECLARATION OF CONFORMITY - MANUFACTURES DECLARATION

Manufacturer: ARITERM OY  
Address: P.O.BOX 59, FIN-43101 SAARIJÄRVI

Equipment: **Biomatic+ 50 pellet heating unit**

Manufacturer assures,

- that in the production of the boiler unit the essential safety requirements of EC council's directive for pressure boilers (97/23/EY) have been complied with. As estimation method of conformity has been used H - module. (Notified body 0424)
- that in the production of the burner following directives have been applied:  
EMC directive 89/336 EEC, low voltage directive 73/23/EEC and the machine directive 98/37/EC
- following standards have been applied:  
EN 303-5 ( class 3 )  
LVD: EN 60335-1, EN 50165:1997-06-27, EN 50165/C1:1998-04-24, EN 50165/A1:2001-04-20  
Machine directive: EN 292-1, EN 292-2  
EMC: EN 55011B, EN 55014, EN 55014-2, EN 61000-3-2, EN 61000-3-3, EN 6000-4-2, EN 6000-4-3, EN 6000-4-4, EN 6000-4-5, EN 6000-4-6, EN 6000-4-11, EN 61000-6-2, EN 61000-6-3:2001

## FÖRSÄKRAN OM ÖVERENSSTÄMMELSE - TILLVERKAREDEKLARATION

Tillverkare: ARITERM OY  
Adress: P.O.BOX 59, FIN-43101 SAARIJÄRVI

Apparat: **Biomatic+ 50 pelletsvärmecentral**

Tillverkare försäkrar,

- att vid tillverkningen av denna panna har man iakttagit väsentliga säkerhetskrav av EG rådets direktiv för tryckkärl (97/23/EY). Som värderingsmetod av överensstämmelse har använts H - modul. (notified body 0424)
- att vid tillverkningen av brännaren har man iakttagit följande direktiven:  
EMC direktivet 89/336/EEC, lågsämningsdirektivet 73/23/EEC samt maskindirektivet 98/37/EC
- följande harmoniserade standarder har tillämpas:  
EN 303-5 ( klass 3 )  
LVD: EN-60335-1  
Maskindirektivet: EN 292-1, EN 292-2  
EMC: EN 55014, EN 610003-3-2, EN 61000-3-3

Arterm Oy

  
Kari Välijaho  
Toimitusjohtaja  
Managing director  
Verkställande direktör

## ■ INSTALLATION PROTOCOL

After installation the burner has to be adjusted. To test every power range, press plus key for 8 seconds in On/Off menu, then can high, low and min modes be tested manually. Returning to normal position: Press minus key once.

**ATTENTION!** In this function, the burner won't stop when the boiler water reaches desired temperature: boiling risk!

Flue gas temp. High	CO	O <sub>2</sub>	CO <sub>2</sub>	Air-fuel ratio
Efficiency	Draught i mm	Fan	Effect %	
Flue gas temp. Low	CO	O <sub>2</sub>	CO <sub>2</sub>	Air-fuel ratio
Efficiency	Draught i mm	Fan	Effect %	
Flue gas temp. Min	CO	O <sub>2</sub>	CO <sub>2</sub>	Air-fuel ratio
Efficiency	Draught i mm	Fan	Effect %	

Retailer / Installer

Installed by

Inst. date

If these instructions are not followed during installation, operation and maintenance, the obligations of Ariterm AB under the warranty regulations are no longer binding. Ariterm reserves the right to alter any details and specifications without prior notice.

**ARITERM** 



Arterm Sweden AB | Flottilvägen 15 39241 Kalmar Sweden  
www.arterm.se | +46 480 442850

# ARTERM

